Service Guide

HP 8990A Peak Power Analyzer

SERIAL NUMBERS

Attached to the rear panel of the instrument is a serial number plate. The serial number is in the form: 0000A00000. The first four digits and the letter are the serial number prefix. The last five digits are the suffix. The prefix is the same for identical instruments; it changes only when a configuration change is made to the instrument. The suffix, however, is assigned sequentially and is different for each instrument.

This manual applies to instruments with serial numbers prefixed 3107A and above.



HP Part No. 08990-90004

© HEWLETT-PACKARD COMPANY 1992
1501 Page Mill Road, Palo Alto California
Printed in USA

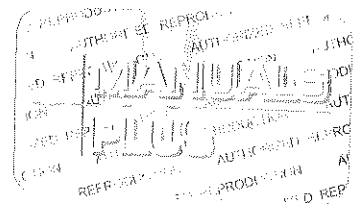

NOTICE

The information contained in this document is subject to change without notice.

HEWLETT-PACKARD MAKES NO WARRANTY OF ANY KIND WITH REGARD TO THIS MANUAL, INCLUDING, BUT NOT LIMITED TO, THE IMPLIED WARRANTIES OF MERCHANTABILITY AND FITNESS FOR A PARTICULAR PURPOSE. Hewlett-Packard shall not be liable for errors contained herein or direct, indirect, special, incidental or consequential damages in connection with the furnishing, performance, or use of this material.

WARRANTY

A copy of the specific warranty terms applicable to your Hewlett-Packard product and replacement parts can be obtained from your local Sales and Service Office.

Herstellerbescheinigung

Hiermit wird bescheinigt, daß dieses Gerät/System in Übereinstimmung mit den Bestimmungen von Postverfügung 1046/84 funkentstört ist.

Der Deutschen Bundespost wurde das Inverkehrbringen dieses Gerätes/System angezeigt und die Berechtigung zur Überprüfung der Serie auf Einhaltung der Bestimmungen eingeräumt.

Zusatzinformation für Meß- und Testgeräte:

Werden Meß- und Testgeräte mit ungeschirmten Kabeln und/oder in offenen Meßaufbauten verwendet so ist vom Betreiber sicherzustellen, daß die Funkentstörbedingungen unter Betriebsbedingungen an seiner Grundstücksgrenze eingehalten werden.

Manufacturer's Declaration

This is to certify that this equipment is in accordance with the Radio Interference Requirements of Directive FTZ 1046/1984. The German Bundespost was notified that this equipment was put into circulation, and has been granted the right to check the equipment type for compliance with these requirements.

Note: If test and measurement equipment is operated with unshielded cables and/or used for measurements in open setups, the user must ensure that under these operating conditions, the radio frequency interference limits are met at the border of his premises.

Safety Considerations

This product and related documentation must be reviewed for familiarization with safety markings and instructions before operation.

This product is a Safety Class I system (provided with a protective earth terminal).

Before Applying Power

Verify that the product is set to match the available line voltage and the correct fuses are installed.

Safety Earth Ground

An uninterruptable safety earth ground must be provided from the main power source to the product input wiring terminals, power cable, or supplied power cable set.

Warning



Any interruption of the protective (grounding) conductor (inside or outside the system) or disconnecting the protective earth terminal will cause a potential shock hazard that could result in personal injury. (Grounding one conductor of a two conductor outlet is not sufficient protection.) In addition, verify that a common ground exists between the unit under test and the system prior to energizing either unit.

Whenever it is likely that the protection has been impaired, the system must be made inoperative and be secured against any unintended operation.

If this system is to be energized via an autotransformer (for voltage reduction) make sure the common terminal is connected to neutral (that is, the grounded side of the mains supply.)

Servicing instructions are for use by service-trained personnel only. To avoid dangerous electric shock, do not perform any servicing unless qualified to do so.

Adjustments described in the manual are performed with power supplied to the system's instruments while protective covers are removed. Energy available at many points may, if contacted, result in personal injury.

Capacitors inside the system's instruments might still be charged even if the system has been disconnected from its source of supply.

For continued protection against fire hazard, replace the line fuses only with 250V fuses of the same current rating and type (for example, normal blow, time delay, etc.). Do not use repaired fuses or short circuited fuse holders.

Safety Symbols

Instruction manual symbol: The product will be marked with this symbol when it is necessary for the user to refer to the instruction manual (see Table of Contents for page references).



Indicates hazardous voltages.



Indicates earth (ground) terminal.

Warning

The **WARNING** sign denotes a hazard. It calls attention to a procedure, practice, or the like which, if not correctly performed or adhered to, could result in personal injury. Do not proceed beyond a **WARNING** sign until the indicated conditions are fully understood and met.

Caution

The **CAUTION** sign denotes a hazard. It calls attention to a procedure, practice, or the like which, if not correctly performed or adhered to, could result in damage to or destruction of part or all of the product. Do not proceed beyond a **CAUTION** sign until the indicated conditions are fully understood and met.

Contents

1. Introduction	
Introduction	1-1
Manual Organization	1-1
Safety Considerations	1-1
Instruments Covered By This Manual	1-2
Manual Updates	1-2
Assumptions About You	1-2
Service Kit	1-2
Electrostatic Discharge	1-2
PC Board Assemblies and Electronic Components	1-3
Test Equipment	1-4
ESD Accessories	1-4
Sales and Service Offices	1-5
How to Return the Instrument for Service	1-5
Service Tag	1-5
Original Packaging	1-5
Other Packaging	1-5
Recommended Test Equipment	1-6
2. Troubleshooting	
Introduction	2-1
Safety Considerations	2-2
Warnings and Cautions	2-2
Before Applying Power	2-2
After-Service Safety Checks	2-3
Recommended Test Equipment	2-3
Service Accessories	2-3
Service Kit	2-3
TORX® Screwdrivers	2-4
Pozidriv Screwdrivers	2-4
Hardware	2-4
Parts and Cable Locations	2-4
Test Point Locations	2-5
Service Aids on Printed Circuit Boards	2-5
Other Service Documents	2-5
Cleaning	2-5
Cleaning Intervals	2-5
Cleaning Solution	2-5
12-Month Cleaning	2-6
After Repair Calibration	2-6
Removing and Installing Firmware	2-6
Vertical Calibration	2-7

Delay Calibration	2-7
If a Calibration Fails	2-8
Block Diagrams	2-9
Block Diagram 1 Theory of Operation	2-9
Peak Power Sensor	2-9
A6 Baseband Board Assembly	2-9
A1 Control Board Assembly	2-10
Acquisition	2-10
Track and Hold	2-10
Postamplifier	2-10
Analog-to-Digital-Converter	2-10
Acquisition Memory	2-10
Triggering and Timebase	2-10
Microprocessor	2-10
A2 Memory Board	2-11
A5 Power Supply	2-11
A8 Sensor Check Source	2-11
Block Diagram Troubleshooting	2-11
To Verify A5 Power Supply Voltages	2-12
To Verify the A3 Display (CRT) Assembly	2-12
To Verify the A8 Sensor Check Source	2-12
To Verify Signals Between the Sensor and the A1 Control Board	2-14
To Verify the Signals Between the A6 Baseband Board and the A1 Control Board	2-16
Isolating the Problem	2-37
To Use the CRT Selftest	2-38
To Use the Keyboard Selftest	2-38
To Verify RF and Video Channel Calibration	2-39
To Verify the Sensor Check Source	2-39
To Verify the Sensor Check Source is Installed and Connected	2-40
To Verify the Sensor Check Source Cabling and Supply Voltage	2-40
To Verify the Sensor Check Source Frequency	2-43
To Verify RF Channel Operation	2-43
To Verify Triggering	2-46
To Run the Selftests	2-47
To Troubleshoot the Peak Power Sensor Input	2-48
To Troubleshoot a Channel 2 or 3 Calibration Failure	2-51
To Troubleshoot a Channel 1 or 4 Calibration Failure	2-51
To Troubleshoot the Fan	2-53
To Check the Fan Mechanically	2-53
To Check the Configuration of the Line Module	2-54
To Check the Line Module Output Voltage	2-55
To Check the Cabling	2-55
To Measure the Fan Voltage	2-56
To Measure the Power Supply Voltages	2-57
To Troubleshoot the Power Supply	2-57
To Check the Cabling and Power Supply Fuse	2-57
To Check the Line Module Voltage	2-58

To Check the Power Supply Voltages	2-59
To Troubleshoot a Bad Fuse	2-60
To Troubleshoot the Microprocessor on the A1 Control Board Assembly	2-63
To Troubleshoot the Display (CRT)	2-65
To Troubleshoot the Keyboard	2-68
To Troubleshoot the Keypad	2-70
To Troubleshoot the Rotary Pulse Generator (RPG)	2-72
3. Disassembly Procedures	
Introduction	3-1
Tools Required	3-2
Service Kit	3-2
Installing an Assembly	3-2
To Remove the A5 Power Supply Assembly	3-5
To Remove the A6 Baseband Boards Housing Assembly	3-5
To Remove the A8 Sensor Check Source Assembly	3-7
To Remove the Rear Panel Assembly	3-7
To Remove the A1 Control Board Assembly	3-8
To Gain Access to the Control Board	3-8
To Remove the CRT Shield	3-8
To Free the Control Board Assembly	3-8
To Disconnect the Toroids	3-9
To Slide the Control Board Assembly Out	3-9
To Remove the A4 Keyboard Assembly	3-9
To Remove the Fan	3-10
To Remove the Feet and Tilt Stand	3-11
To Remove the CRT Monitor Assembly	3-11
To Access The Control Board Assembly	3-11
To Remove the Control Board Assembly	3-12
To Remove the Sweep Board	3-12
To Remove the CRT	3-13
To Remove the Front Panel Connectors	3-13
To Access The Connector Block	3-13
To Remove the Connectors	3-14
4. Replaceable Parts	
Introduction	4-1
Abbreviations	4-1
Replaceable Parts List	4-1
Illustrated Replaceable Parts List	4-2
Exchange Assemblies	4-2
Parts List Backdating	4-2
Parts List Updating	4-3
Ordering Information	4-3
Parts Identification	4-3
Recommended Spares List	4-3

5. Reference	
Introduction	5-1
Service Menu	5-1
Remote Commands	5-3
MASK	5-4
PAGAIN	5-6
:SENSOR: ATODVALUE?	5-8
SERIAL:SENSOR	5-9
STICKDAC	5-10
ZVALUE	5-11
selftest menu	5-12
ram Test	5-13
rom Test	5-13
acquisition Test	5-13
miscellaneous Tests	5-13
Vertical Calibration Error Codes	5-14
Index	

Figures

1-1. Static-Safe Workstation	1-3
2-1. Service Kit Line Module	2-4
2-2. Sensor Check Source DC Cable	2-13
2-3. Channel 1 and Channel 4 DC Cable Locations	2-15
2-4. A1J18 and A1J19 Pin Identification Drawing	2-16
2-5. Connector for W16 and W17	2-17
2-6. Interconnection Diagram	2-19
2-7. Overall Block Diagram	2-21
2-8. Acquisition Interconnect Block Diagram	2-23
2-9. Acquisition Block Diagram	2-25
2-10. Timebase and Trigger Block Diagram	2-27
2-11. Microprocessor Block Diagram	2-29
2-12. CRT Control and CRT Block Diagram	2-31
2-13. Baseband Board Block Diagram	2-33
2-14. HP 8990A Peak Power Analyzer Major Assemblies	2-35
2-15. HP 8990A Peak Power Analyzer Cable Assemblies	2-36
2-16. Display Selftest	2-38
2-17. Sensor Check Source DC Cable	2-42
2-18. Sensor Check Source Modulation Cable	2-45
2-19. Channel 1 and Channel 4 DC Cable Locations	2-49
2-20. A1J18 and A1J19 Pin Identification Drawing	2-50
2-21. A6 Baseband Covers	2-52
2-22. Fuse Block Removal	2-54
2-23. A5 Power Supply Test Points	2-57
2-24. A5 Power Supply Test Points	2-60
2-25. Fuse Block Removal	2-61
2-26. A5 Power Supply Test Points	2-64
2-27. A5 Power Supply Test Points	2-66
2-28. A5 Power Supply Test Points	2-69
2-29. Shorting the Keypad Traces	2-72
3-1. Major Assemblies	3-3
3-2. Cable Assemblies	3-4
3-3. A6 Baseband Housing Shield Covers	3-6
4-1. HP 8990A Peak Power Analyzer Cable Assemblies	4-9
4-2. Figures Orientation Drawing	4-11
4-3. Cabinet Parts	4-13
4-4. Power Supply, Baseband Housing, and Sensor Check Source Illustrated Parts Breakdown	4-15
4-5. Front Panel Illustrated Parts Breakdown	4-17
4-6. Front Panel Connectors Illustrated Parts Breakdown	4-19
4-7. CRT Shield, Memory Board, and Line Module Illustrated Parts Breakdown	4-21

4-8. CRT and CRT Driver Board Illustrated Parts Breakdown	4-23
4-9. Rear Panel Illustrated Parts Breakdown	4-25
4-10. Control Board Illustrated Parts Breakdown	4-27
5-1. Service Menu Selections	5-2
5-2. Selftest Menu	5-12
5-3. Results of Selftest	5-13

Tables

2-1. Peak Power Sensor Signal Levels	2-14
2-2. Line Module Output Voltages	2-55
2-3. Line Module Output Voltages	2-58
2-4. CRT Sweep Cable Voltages and Signals	2-67
4-1. Part Numbers for Exchange Assemblies	4-2
4-2. Reference Designations	4-4
4-3. Abbreviations	4-4
4-4. Multipliers	4-5
4-5. Replaceable Major Assemblies	4-7
4-6. Cable Assemblies	4-8
5-1. Vertical Calibration	5-15
5-1. Vertical Calibration	5-16

1
2
3
4
5
6
7
8
9
10
11
12
13
14
15
16
17
18
19
20
21
22
23
24
25
26
27
28
29
30
31
32
33
34
35
36
37
38
39
40
41
42
43
44
45
46
47
48
49
50
51
52
53
54
55
56
57
58
59
60
61
62
63
64
65
66
67
68
69
70
71
72
73
74
75
76
77
78
79
80
81
82
83
84
85
86
87
88
89
90
91
92
93
94
95
96
97
98
99
100

Introduction

Introduction

The service information for the HP 8990A Peak Power Analyzer comes in two binders.

The *HP 8990A Service Guide* binder provides information needed to repair the Peak Power Analyzer to the assembly level. The *HP 8990A Peak Power Analyzer Component-Level Information* binder provides component-level information for the repair of individual instrument assemblies. The binder contains Component-Level Information Packets (CLIPs) for selected assemblies. Each CLIP contains component-level schematics, a component parts list, and illustrations for component location by reference designator.

Calibration information is in the HP 8990A Calibration Guide (HP part number 08990-90023). The Calibration Guide contains the performance tests and adjustments for the Peak Power Analyzer.

The Service Guide and Calibration Guide are both part of Option 915, service documentation.

Manual Organization

The service guide includes the following chapters:

Chapter 1, INTRODUCTION, covers manual organization, instrument versions, and electrostatic discharge information.

Chapter 2, TROUBLESHOOTING, contains the block diagrams and procedural troubleshooting.

Chapter 3, DISASSEMBLY PROCEDURES, contains instructions for the removal and replacement of major assemblies.

Chapter 4, REPLACEABLE PARTS, contains information needed to order assemblies for the instrument.

Chapter 5, REFERENCE, contains descriptions of the Service Menu, calibration errors, and the service HP-IB commands.

Safety Considerations

This product is a Safety Class 1 instrument, that is, it has a protective earth terminal. This Service Guide should be reviewed for familiarization with safety markings and instructions before operation.

Refer to the Safety Considerations pages found at the beginning of this manual for a summary of the safety information. Safety information for the various service functions appears in appropriate places throughout this manual.

**Instruments Covered By
This Manual**

Attached to the rear panel of this instrument is a serial number plate. The serial number is in the form: 0000A00000. The first four digits and the letter are the serial number prefix. The last five digits are the suffix. The prefix is the same for identical instruments; it changes only when a configuration change is made to the instrument. The suffix assignment is sequential and is different for each instrument. The contents of this manual apply directly to instruments having the serial number prefix(es) listed under "Serial Numbers" on the title page.

Manual Updates

Different versions of this instrument are identified by a change in serial number prefix. The information for these different versions can be found either in the text of this manual or in a *Manual Updates* package. The package contains information that explains how to adapt this manual to the newer instrument version.

In addition to change information, the *Manual Updates* package may contain information for correcting errors in the manual. The package identification is the manual print date and part number, both appear on the back cover of this manual.

Assumptions About You

The procedures in this manual assume that you have the tools and equipment to perform each service task. To find what tools and equipment belong to each service task, refer to the chapter containing the task.

Service Kit

The HP 8990A Service Kit contains a selection of cables and tools to aid in servicing the HP 8990A Peak Power Analyzer. Order HP part number 08990-60045.

Electrostatic Discharge

Electrostatic Discharge (ESD) can damage or destroy electronic components. All work performed on assemblies containing electronic components should be done ONLY at a static-safe work station. See figure 1-1.

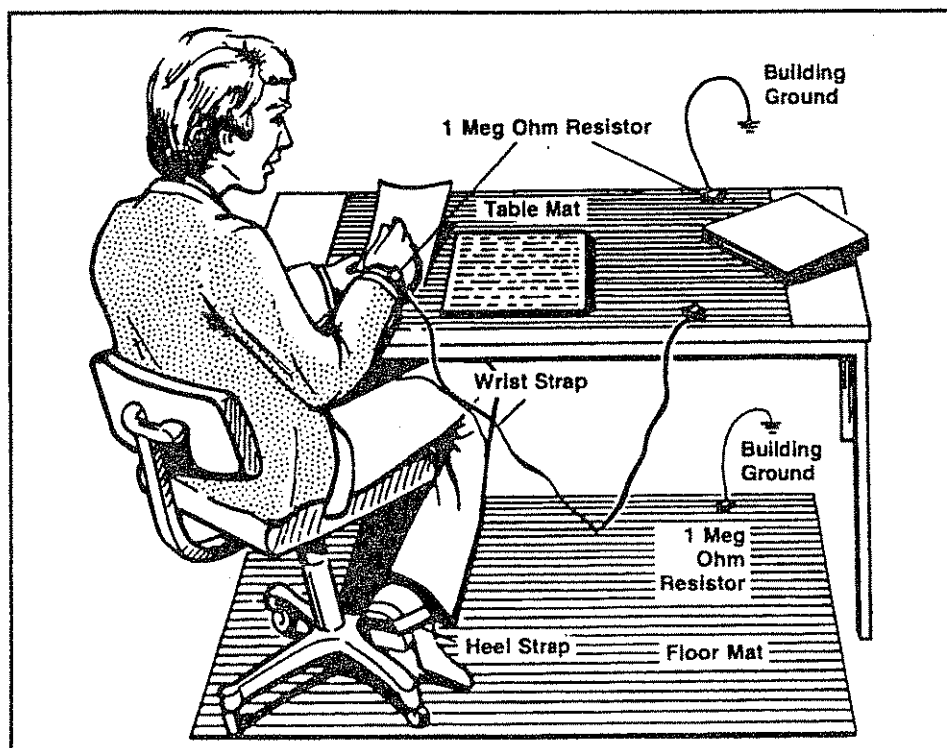

Figure 1-1. Static-Safe Workstation

PC Board Assemblies and Electronic Components

Caution



- Handle these items ONLY at a static-safe work station.
- Store or transport these items ONLY in static-shielding containers.

Do not use erasers to clean the PC board edge connector contacts. Erasers generate static electricity and remove the thin gold plating, which degrades the electrical quality of the contacts.

Do not use paper of any kind to clean the edge connector contacts. Paper or lint particles left on the contact surface can cause intermittent electrical connections. Do not touch the edge connector contacts or trace surfaces. Always handle board assemblies by the edges.

Clean PC board assembly edge connector contacts with a lint-free cloth and a solution of 80% electronics-grade isopropyl alcohol and 20% deionized water. Perform this procedure only at a static-free work station.

Test Equipment

- Before connecting a coaxial cable to an instrument connector for the first time each day, momentarily ground the center and outer conductors of the cable.
- Personnel should be grounded with a resistor-isolated wrist strap before touching the center pin of any connector and before removing any assembly from the instrument.
- Properly earth-ground all instruments to prevent buildup of static charge.

ESD Accessories

The following static-safe accessories may be ordered from a Hewlett-Packard sales or service office:

Description	Dimensions	HP Part No.
3M Static Control Mat Ground Wire, 4.6m (15 ft) Wrist Strap and Attachment Cord	0.6m x 1.2m (2 ft. x 4 ft.)	9300-0797
Wrist Strap Cord	1.5m (5 ft.)	9300-1243
Wrist Strap (Large)		9300-1242
Wrist Strap (Small)		9300-1099
ESD Heel Strap (<i>Reusable 6 to 12 Months</i>)		9300-1185
Shoe Ground Strap (<i>One-Time Use Only</i>)		9300-0793

The ESD accessories listed below may be ordered from:

Hewlett-Packard Company
Computer Supplies Operations
1320 Kifer Road
Sunnyvale, California 94086
Phone: (408) 738-8858

Description	Dimensions	HP Part No.
Static Control Mat Black, Hard-Surface	1.2m x 1.5m (4 ft. x 5 ft.)	HP 92175A
Static Control Mat Brown, Soft-Surface	2.4m x 1.2m (8 ft. x 4 ft.)	HP 92175B
Static Control Mat Black, Hard-Surface, Small	1.2m x 0.9m (4 ft. x 3 ft.)	HP 92175C
Static Control Mat, Tabletop	58cm x 76cm (23in x 30in)	92175T
Anti-Static Carpet	1.8m x 1.2m (6 ft. x 4 ft.)	HP 92176A (natural color) HP 92176C (russet color)
Anti-Static Carpet	2.4m x 1.2m (8 ft. x 4 ft.)	HP 92176B (natural color) HP 92176D (russet color)

Sales and Service Offices

Hewlett-Packard has sales and service offices around the world providing complete support for the HP 8990A Peak Power Analyzer. To obtain servicing information or to order replacement parts, contact the nearest Hewlett-Packard Sales and Service Office listed on the inside rear cover of this manual. In any correspondence, refer to the instrument by its model number and any pertinent assembly part numbers.

How to Return the Instrument for Service

Service Tag

If you are returning the Peak Power Analyzer to Hewlett-Packard for servicing, fill in and attach a blue service tag. Several service tags are supplied at the back of this guide.

Please be as specific as possible about the nature of the problem. If you have recorded any error messages that appeared on the screen or have any other specific data on the performance of the instrument, please send a copy of this information with the unit.

Original Packaging

Before shipping, pack the unit in the original factory packaging materials. If the original materials were not retained, identical packaging materials are available through any Hewlett-Packard office.

Other Packaging

Caution



Module damage can result from using packaging materials other than those specified. Never use styrene pellets, in any shape, as packaging materials. They do not adequately cushion the equipment or prevent it from shifting in the carton. They also cause equipment damage by generating static electricity.

You can repackage the module with commercially available materials as follows:

1. Attach a completed service tag and any other failure information to the instrument.
2. Wrap the module in anti-static plastic to reduce the possibility of ESD damage.
3. Use a strong shipping container. A double-walled, corrugated cardboard carton with 159-kg. (350-lb.) bursting strength is adequate. The carton must be both large enough and strong enough to accommodate the instrument and at least three to four inches of packing material on all sides.
4. Securely pack the instrument in three to four inches of packing material to prevent it from moving around in the carton. If packing foam is not available, the best alternative is to use S.D.-240 Air Cap™, from Sealed Air Corporation in Commerce, California, 90001. This material is a plastic sheet of 1¼-inch air bubbles. Use the pink-colored Air Cap to reduce static electricity. Wrap the instrument several times in this material to protect it and to prevent it from moving in the carton.
5. Seal the shipping container securely with strong nylon adhesive tape.
6. Mark the shipping container "FRAGILE, HANDLE WITH CARE" to encourage careful handling.
7. Retain copies of all shipping papers.

Recommended Test Equipment

Table 1-1. Equipment Used in Servicing

Instrument	Critical Specifications	Recommended Model	Use ¹
Digital Voltmeter	Resolution: 0.01 volt	HP 3456A	T
Frequency Counter	Frequency: 1.05 GHz Resolution: 0.01 GHz	HP 5343A	T
Oscilloscope	Bandwidth: 100 MHz	HP 54111D	T
Power Meter	Single Channel	HP 437B	T
Power Sensor	Frequency: 1.05 GHz Power Range: 10 dBm	HP 8482A	T

¹T=Troubleshooting, A=Adjustments, P=Performance Tests.

Troubleshooting

Introduction

This is the troubleshooting chapter for the HP 8990A Peak Power Analyzer. The troubleshooting strategy is to isolate the problem to a major assembly. If it is desired to isolate the problem to a component of a major assembly, refer to the *HP 8990A Component-Level Information* manual.

Two methods of troubleshooting are being provided:

Block Diagram Level

Procedural

The block diagram level troubleshooting provides the voltage and power levels for the signals between the major assemblies. These levels represent what should be seen when the Peak Power Analyzer is operating normally. This procedure might be used by the technician that does not like to use a structured procedure. Block diagram troubleshooting begins with the section titled "Block Diagram 1 Theory of Operation."

The procedural troubleshooting guides you step by step in isolating the failed assembly. The procedure assumes that there is a problem, but the source of the problem is unknown. The troubleshooting is written to find multiple problems, if they exist. Therefore, if a single problem exists there is no need to complete the entire troubleshooting once the problem has been isolated. This procedure may be used by the newer technician or the technician that prefers to use a step by step procedure. The procedural troubleshooting begins with the section titled "Isolating the Problem."

Both the block diagram and procedural troubleshooting refer to major assemblies and cable assemblies in the Peak Power Analyzer. Figures 2-14 and 2-15 are going to be helpful in identifying and locating these assemblies.

Safety Considerations

Warnings and Cautions

Pay attention to WARNINGS and CAUTIONS. They must be followed for your protection and to avoid damage to the equipment.

Before Applying Power

Caution



Verify that the instrument is set to match the available line (mains) voltage and that the correct fuse is installed. An uninterrupted safety earth ground must be provided from the main power source to the instrument input wiring terminals or power cable.

Warning



Maintenance described herein is performed with power supplied to the instrument and with protective covers removed. Such maintenance should be performed only by service-trained personnel who are aware of the hazards involved (for example, fire and electrical shock). Where maintenance can be performed without power supplied, the power should be removed.

Any interruption of the protective (grounding) conductor (inside or outside the instrument) or disconnecting the protective earth terminal will cause a potential shock hazard that could result in personal injury. (Grounding one conductor of a two conductor outlet is not sufficient protection.) In addition, verify that a common ground exists between this instrument and the test equipment prior to energizing either unit.

Whenever it is likely that the protection has been impaired, the instrument must be made inoperative and be secured against any unintended operation.

If this instrument is to be energized via an autotransformer (for voltage reduction) make sure that the common terminal is connected to neutral (that is, the grounded side of the mains supply).

Servicing instructions are for use by service-trained personnel only. To avoid dangerous electric shock, do not perform any servicing unless qualified to do so.

Energy available at many points may, if contacted, result in personal injury.

Capacitors inside the instrument may still be charged even if the instrument has been disconnected from its source of supply.

For continued protection against fire hazard, replace the line fuse(s) only with 250 V fuse(s) of the same current rating and type (for example normal blow, time delay, etc.). Do not use repaired fuses or short circuited fuseholders.

Caution

Unplug the instrument before disconnecting or removing any boards. Some boards contain devices that can be damaged if the board is removed when the power is on. There are several components including MOS and CMOS devices that can be damaged by electrostatic discharge. Use conductive foam and grounding straps when servicing sensitive components. Carefully unplug ICs in high-grip sockets.

After-Service Safety Checks

Visually inspect the interior of the instrument for any signs of abnormal internally generated heat, such as discolored printed circuit boards or components, damaged insulation, or evidence of arcing. Determine and remedy the cause of any such condition.

Using a suitable ohmmeter, check resistance from instrument enclosure to ground pin on power cord plug. The reading must be less than one ohm. Flex the power cable while making this measurement to determine whether intermittent discontinuities exist.

Check any indicated rear-panel ground terminals that are marked, using the above procedures.

Check resistance from instrument enclosure to line and neutral (tied together) with the on/off switch in the ON (|) position and the power source disconnected. The minimum acceptable resistance is two megohms. Replace any component that results in a failure.

Check the line fuse to verify that a correctly rated fuse is installed.

Recommended Test Equipment

Test equipment and accessories required to maintain the instrument are listed in table 1-1, "Recommended Test Equipment." Equipment other than that listed may be used if it meets the critical specifications listed in the table.

Service Accessories**Service Kit**

Some procedures require the use of special tools and cables. The HP 8990A Service Kit contains a selection of cables and tools to aid in servicing the HP 8990A Peak Power Analyzer. Order HP part number 08990-60045.

Warning

When the service kit line module is connected to the power cord, turned ON, and NOT connected to the power supply, a potential shock hazard exists at the line module connector. See figure 2-1.

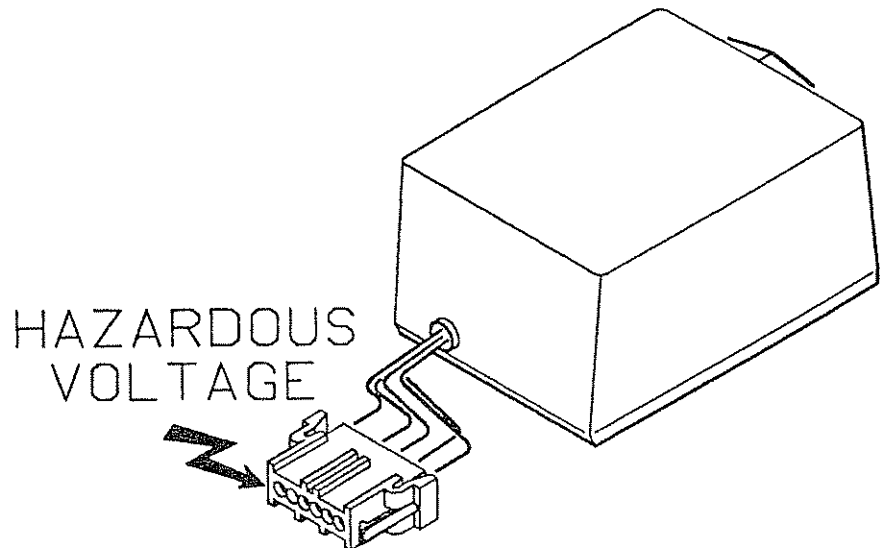

Figure 2-1. Service Kit Line Module

TORX® Screwdrivers

Most of the screws in the Peak Power Analyzer are TORX® screws. Remove these screws with a TORX® screwdriver. The part number of the #10 TORX® screwdriver is HP 8710-1623. The part number of the #15 TORX® screwdriver is HP 8710-1622.

Pozidriv Screwdrivers

Some screws in the instrument appear to be Phillips type, but are not. To avoid damage to the screw head slots, Pozidriv screwdrivers should be used. The part number of the No. 1 Pozidriv is HP 8710-0899. The part number of the No. 2 Pozidriv is HP 8710-0900.

Hardware

The instrument has a mixture of Unified National (inch) and metric screws. The metric screws are defined in Industrial Fasteners publication (IFI 500). Do not use a metric screw in a Unified National nut, or a metric nut with a Unified National screw because thread damage will occur.

Parts and Cable Locations

The locations of individual components mounted on printed circuit boards are available for selected instrument assemblies. The information for these assemblies is provided in the accompanying *HP 8990A Peak Power Analyzer Component-Level Information* manual.

Each tabbed section in the Component-Level Information manual contains the parts list, component-location diagram, and schematic for that specified assembly.

The part reference designation is the assembly designation plus the part designation. For example, A6R9 is R9 on the A6 assembly. For specific component descriptions and ordering information, see the parts list in the Component-Level Information manual for that board.

Chassis and frame parts, as well as mechanical parts and cables (W), are identified in illustrated parts breakdowns (IPBs) in chapter 4.

Test Point Locations

Most test points are indicated on the actual circuit-board assemblies. Test and measurement points called out in the troubleshooting procedures are shown on the component-location diagrams in the Component-Level Information manual.

Service Aids on Printed Circuit Boards

Service aids on printed circuit boards include test points, indicator lights, some reference designations, and assembly part numbers.

Other Service Documents

Service Notes, Manual Update Packages, and other service literature are available through Hewlett-Packard. For further information, contact your nearest Hewlett-Packard office.

Cleaning

Cleaning Intervals

Warning



Before cleaning, make sure the instrument is disconnected from the power source. This is to eliminate the possibility of electrical shock.

Caution



In procedures that call for a vacuum cleaner to remove dust, do not use a blower or compressed air. Doing so will cause the dust to be transferred throughout the instrument.

Hewlett-Packard recommends a 12-month interval between cleaning for some parts of the instrument. But, cleaning intervals are mostly dependent upon where the instrument is used. The instrument should be cleaned more often if it is in a dusty or very humid area.

Cleaning Solution

Hewlett-Packard recommends using either of two cleaning solutions on printed circuit (PC) board edge connectors. For best cleaning results, we recommend an ammonium hydroxide solution (NH₄OH, 29.5% NH₃ by weight). But, a concentrated solution of ammonia requires the use of gloves, eye goggles, and proper ventilation. The second recommendation is an 80:20 solution of isopropyl alcohol and water (IPA/H₂O). This should serve as a satisfactory cleaner where one would not want to use ammonium hydroxide.

12-Month Cleaning

At 12-month intervals the instrument cover and rear panel should be removed to gain access to the cooling fan.

Wipe the instrument fan with a clean cloth or tissue, or vacuum for dust.

Remove each printed circuit board, and clean the component side of the board with compressed air. To remove the boards, refer to chapter 3, Disassembly Procedures. Return the boards to the instrument.

After cleaning, reinstall the cover.

After Repair Calibration

Once the Peak Power Analyzer is repaired, it may be necessary to calibrate the instrument. Refer to the HP 8990A Calibration Guide to determine when it is necessary to use the performance tests and adjustments.

Removing and Installing Firmware

Use the following procedure when removing and installing new firmware in the Peak Power Analyzer:

1. Use a wrist strap and observe all Electrostatic Discharge (ESD) precautions when removing and installing the new firmware.
2. Set the rear panel line switch to OFF ().
3. Disconnect the power cord from the line module/switch assembly.
4. Remove six screws from the top and two screws from each side of the Peak Power Analyzer's cabinet with a #10 TORX® screwdriver.
5. Lift the top cover off.
6. Loosen the screw that attaches the A2 Memory Board (see figure 2-14) to the rear chassis of the instrument.
7. While holding the spacer that is between the memory board and rear chassis, pull the screw through the hole in the memory board, and remove the spacer.

8. Gently disconnect the A2 Memory Board from the A1 Control Board Assembly.
9. Gently remove the ROMS (U2 and U3) from the A2 Memory Board and install the new ROMS. Be careful not to bend the pins.
10. Reinstall the A2 Memory Board.
11. Replace the instrument cover.
12. Connect the power cord to the line module/switch assembly.
13. Set the rear panel CALIBRATOR switch to UNPROTECTED.
14. Hold down any front panel key while you simultaneously turn on the instrument. Release the key when you see the turn-on picture on the display.
15. At turn-on the Peak Power Analyzer will detect that new firmware was installed. Default calibration factors will be loaded, and you will be prompted to recalibrate the instrument.
16. Perform the following calibrations:
 - Vertical Calibration
 - Delay Calibration

Vertical Calibration

Perform a vertical calibration of all channels, using the following steps:

1. Press the front panel **UTIL** menu key.
2. Select the **instr cal menu** softkey. It may be necessary to use the **more** softkey to display the **instr cal menu** softkey.
3. Press the top softkey until **0** is displayed and "vertical cal" is highlighted.
4. Press the **channel** softkey until **all** is highlighted.
5. Press the **start cal** softkey. Follow the displayed instructions.
6. Whether a calibration PASSED or FAILED is displayed along the left side of the screen

If a vertical calibration fails, refer to "If a Calibration Fails" at the end of this procedure.

Delay Calibration

Perform a delay calibration of all channels, using the following steps:

Note

Use the BNC cable (HP part number 10503A) that is supplied with the Peak Power Analyzer to make the connection from the rear panel AC CAL output. Do not use a BNC tee with the cable. If the supplied cable is not used, the accuracy of the time skew cannot be guaranteed. The cable is 1.5 metres and has a delay of 5 ns \pm 10%.

For specified accuracy, the sensor(s) used in delay cal should be the sensor(s) used for the measurement. But, if the greatest time accuracy is not needed, any sensor with the same cable length (1.5 metres versus 6 metres) is generally close enough.

1. Press the front panel **UTIL** menu key.
2. Select the **instr cal menu** softkey. It may be necessary to use the **more** softkey to display the **instr cal menu** softkey.
3. Press the top softkey until 1 is displayed and "delay cal" is highlighted.
4. Press the **channel** softkey until the desired channel is highlighted.
5. Press the **start cal** softkey. Follow the displayed instructions.

If a delay calibration fails, refer to the next section, "If a Calibration Fails." When the calibrations are complete, reset the rear panel CALIBRATOR switch to PROTECTED.

If a Calibration Fails

If vertical cal fails, verify the following:

- Is the setup correct?
- For channels 1 and 4, was the peak power sensor disconnected from the Peak Power Analyzer, or is the signal at the peak power sensor at most -60 dBm.
- For channels 2 and 3, was the connection made to the rear panel DC CAL connector?

If the items mentioned have been checked out, refer to the "Isolating the Problem" section in this chapter.

If delay cal fails, verify the following:

- Was vertical cal done recently?
- Was the BNC cable (HP 10503A) supplied with the Peak Power Analyzer used for the calibration?
- Was the BNC cable connected to the rear panel AC CAL connector?

If the items mentioned have been checked out, refer to the "Isolating the Problem" section in this chapter.

Block Diagrams

The major assemblies of the Peak Power Analyzer are shown using seven block diagrams:

- Block Diagram 1, Overall Block
- Block Diagram 2, Acquisition Interconnect Block
- Block Diagram 3, Acquisition Block
- Block Diagram 4, Timebase and Trigger Block
- Block Diagram 5, Microprocessor Block
- Block Diagram 6, CRT Control and CRT Block
- Block Diagram 7, Baseband Board Block

Theory of operating is provided for the overall block diagram, Block Diagram 1.

Block Diagram 1 Theory of Operation

The following discussion will cover the upper level theory of operation for the peak power sensor and the following Peak Power Analyzer assemblies:

- A1 Control Board Assembly
- A2 Memory Board Assembly
- A5 Power Supply Assembly
- A6 Baseband Board Assembly
- A8 Sensor Check Source Assembly

Peak Power Sensor

The peak power sensor has a dynamic range of -32 to $+20$ dBm and a frequency range of 500 MHz to 40 GHz, depending on the sensor being used. Calibration data is stored on an EEPROM supplied within the sensor.

The pulsed RF signal is input to the sensor and envelope detected. Microprocessor controlled signal switching establishes a zero input power. The detected signal is amplified.

A6 Baseband Board Assembly

The detected signal moves from the peak power sensor to the Peak Power Analyzer. The video signal undergoes 94 dB of switchable gain on the A6 Baseband Board. The dc-coupled amplifiers, switched with GaAs switch ICs, fulfill a dual task. First, they output the sensor video signal in coarse gain steps into the limited dynamic range of the track-and-hold circuit, on the A1 Control Board, and later the analog-to-digital converter (ADC). Second, they limit broadband noise. The bandwidth of the amplifiers changes from > 150 MHz for higher signal levels to 2.5 kHz for the lowest power decade.

A1 Control Board Assembly

The A1 Control Board contains the following circuitry:

- Acquisition
- Triggering and Timebase
- Microprocessor
- Digital Display Processing

Acquisition

Track and Hold. The pulse envelope signal, roughly scaled by the baseband circuits, is subsequently sampled by the track-and-hold circuit at a rate of 10 MHz. Ideally, the track-and-hold bridge is modeled as a SPST switch, closed during the track mode for 50 ns and open during the hold mode for 50 ns.

Postamplifier. The hold level of the track-and-hold output then passes through the postamplifier with fifteen fine gain steps. In combination with the baseband gain, the postamplifier guarantees that any input level in the specified -32 to $+20$ dBm range can fill the analog-to-digital-converter window.

Analog-to-Digital-Converter. During the 50 ns hold period, the 8-bit flash ADC digitizes the waveform. The 8-bit resolution of the flash converting ADC represents a bit range of 0 to 255. This translates to 24 dB of dynamic range referenced to the sensor input if the sensor was to operate solely in the square-law range, or to 48 dB for operation strictly in the linear range. The wide transition range between square and linear operation causes most applications to fall between these numbers.

Acquisition Memory. The ADC output is captured by the 2K-byte-wide circular acquisition memory.

Triggering and Timebase

The task of accurate time placement of the received pulse envelope is carried out by the powerful trigger and time-base ICs. A 40-MHz crystal oscillator is responsible for the time-base accuracy of 0.005%.

Microprocessor

A 68000 microprocessor controls the signal processing and the monochromatic 9-in display.

A2 Memory Board	The control code resides on the A2 Memory Board and takes up roughly 600K bytes of ROM. The board has 512K bytes of system DRAM.
A5 Power Supply	The power supply is a switching supply operating nominally at 40 kHz.
A8 Sensor Check Source	The sensor check source supplies a pulsed or CW signal of +10 dBm \pm 0.5 dB at 1050 MHz. The check source serves two purposes. First, it acts as a source to verify the operation of the peak power sensor. Second, it supplies a signal for time calibration of the trigger circuits and the timing between the four channels.

Block Diagram Troubleshooting

Note



When performing the procedures, it is important that you note how the cable assemblies are dressed (routed) within the Peak Power Analyzer. For example, if cable assemblies W21 and W22 (see figure 2-15 for their location within the instrument) are not dressed properly, low level accuracy can be effected.

The level of troubleshooting for the Peak Power Analyzer is assembly level. If it is desired to troubleshoot to the component level, refer to the *HP 8990A Peak Power Analyzer Component-Level Information* manual.

Unlike the procedural troubleshooting, the following information will not lead the technician step by step. It is assumed that the technician will use the information and the block diagrams to determine the most likely assembly that may have failed.

By using the following information, the interconnection diagram, and the block diagrams, it should be possible to isolate a problem to one of the following assemblies:

- A1 Control Board
- A2 Memory Board
- A3 CRT Monitor
- A5 Power Supply
- A6 Baseband Board
- A8 Sensor Check Source

Use figures 2-14 and 2-15 to locate the major assemblies and cable assemblies mentioned in the text.

The following information lists the voltage and power levels that will be measured when the Peak Power Analyzer is operating properly.

To Verify A5 Power Supply Voltages

The A5 Power Supply is shown on Block Diagram 1. To decide if the A5 Power Supply is functioning properly, use the procedure "To Troubleshoot the Power Supply," which is in the "Isolating the Problem" section of this chapter.

To Verify the A3 Display (CRT) Assembly

The A3 Display (CRT) is shown on Block Diagram 6. To determine if the A3 Display is functioning properly, use the procedure "To Troubleshoot the Display (CRT)," which is in the "Isolating the Problem" section of this chapter.

To Verify the A8 Sensor Check Source

The A8 Sensor Check Source is shown on Block Diagram 3. If the A8 Sensor Check Source and the A1 Control Board are functioning properly together, the following can be measured at the indicated points:

- The front panel SENSOR CHECK is a 10 dBm \pm 0.5 dB, 1.05 GHz signal with the `check source` softkey set to pulse or CW. The `check source` softkey is part of the front panel Utility Menu.
- Pin 1 of A1J21 will change states as the `check source` softkey is turned on and off.
- Pin 2 of A1J21 is +12 Vdc.
- Pin 3 of A1J21 will change states as the `check source` softkey is switched between pulse and CW.

To gain access to the A1J21 connector, use the following steps:

1. Set the rear panel line switch to OFF ().
2. Disconnect the power cable from the line module/switch assembly.
3. Remove six screws from the top and two screws from each side of the Peak Power Analyzer's cabinet with a #10 TORX® screwdriver.
4. Lift the top cover off.
5. Perform the following procedures in the disassembly chapter of this manual: "To Remove the A5 Power Supply" and "To Remove the A6 Baseband Boards Housing."
6. Perform the following steps in preparation of reconnecting the power supply outside of the instrument:
 - a. Remove the two screws securing the line module/switch to the rear panel.
 - b. Slide the line module/switch halfway out the back panel.

- c. Loosen the screw that attaches the A2 Memory Board assembly to the rear chassis of the instrument.
 - d. While holding the spacer that is between the memory board and rear chassis, pull the screw through the hole in the memory board, and remove the spacer.
 - e. Gently disconnect the A2 Memory Board from the A1 Control Board Assembly.
 - f. Gently pull (toward the front of the instrument) on the CRT shield until the shield disengages from the rear panel.
 - g. Remove the shield by sliding it to the side. You might have to lift up slightly on the rear of the shield while sliding it.
 - h. Disconnect W27 at A1J9.
7. Reconnect the A2 Memory Board Assembly.
 8. Reconnect the A5 Power Supply outside of the instrument using the cable extender and line module from the service kit.
 9. Disconnect W20 at A1J21. See figure 2-2.

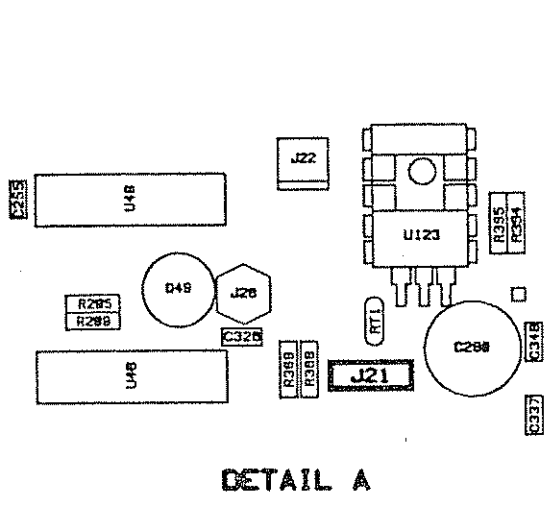
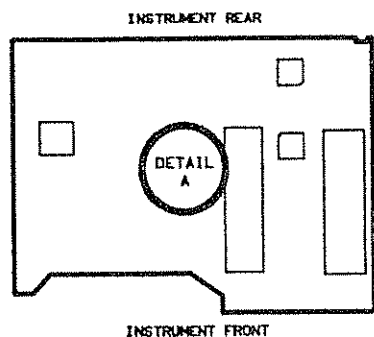

Figure 2-2. Sensor Check Source DC Cable

10. Connect the power cord to the line module/switch assembly and set the line switch to ON (|).
11. Verify the voltages and signals on A1J21. Identify the pin numbers of A1J21 by noting the wire colors of W20 and where they connect to A1J21. For example, pin 2 would connect to a red wire.

Turn the instrument OFF and reassemble the instrument.

**To Verify Signals
Between the Sensor
and the A1 Control
Board**

The following information will help to determine if a problem exists with the peak power sensor or with the A1 Control Board. Connectors A1J18 and A1J19 are shown on Block Diagram 2. The voltage levels input to the peak power sensor should be as shown in the following table:

Table 2-1. Peak Power Sensor Signal Levels

Connector	Pin Number	Voltage Level
J18	1	-12.0 to -11.0
J19	1	-12.0 to -11.0
J18	3	+4.0 to +6.0
J19	3	+4.0 to +6.0
J18	4	+10.0 to +12
J19	4	+10.0 to +12
J18	10	-0.050 to 0.050
J19	10	-0.050 to 0.050

To gain access to the A1J18 and A1J19 connectors, use the following steps:

1. Set the rear panel line switch to OFF (O).
2. Disconnect the power cord from the line module/switch assembly.
3. Remove six screws from the top and two screws from each side of the Peak Power Analyzer's cabinet with a #10 TORX® screwdriver.
4. Lift the top cover off.
5. Perform the following procedures in the disassembly chapter of this manual: "To Remove the A5 Power Supply", "To Remove the A6 Baseband Boards Housing", and "To Remove the A8 Sensor Check Source Assembly."
6. Depending on the channel in question, disconnect the cable at A1J18 (W26; CH 1) or A1J19 (W23; CH 4) on the A1 Control Board. See figure 2-3.

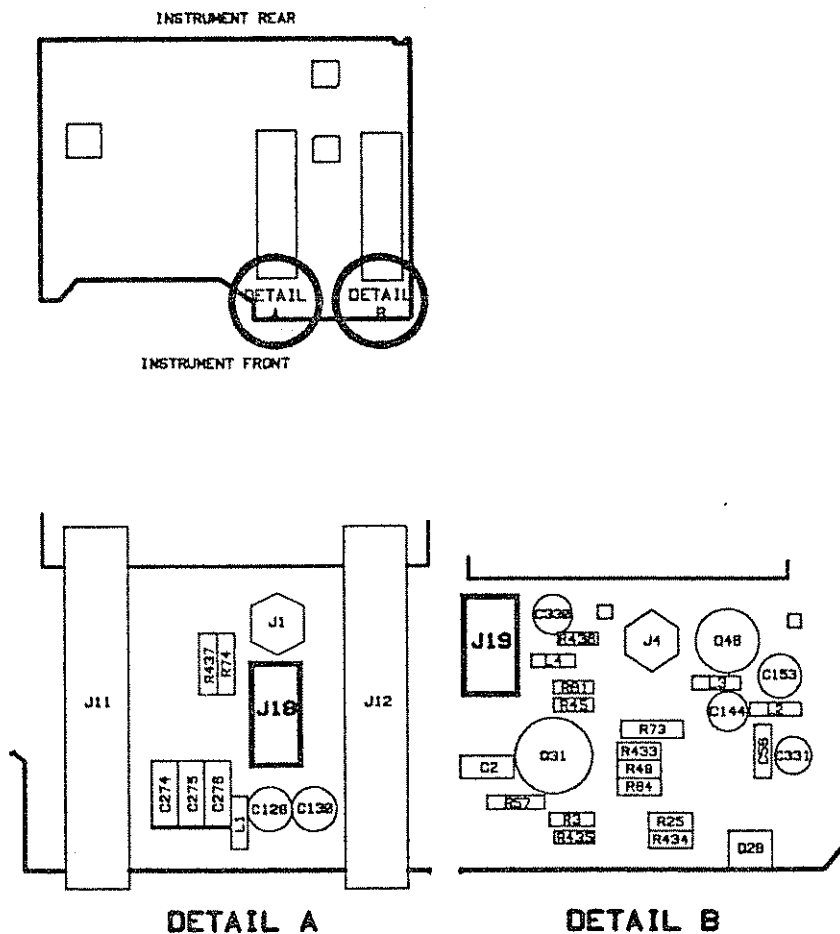

Figure 2-3. Channel 1 and Channel 4 DC Cable Locations

7. Perform the following steps in preparation to connecting the power supply outside of the instrument:
 - a. Remove the two screws securing the line module/switch to the rear panel.
 - b. Slide the line module/switch halfway out the back panel.
 - c. Loosen the screw that attaches the A2 Memory Board assembly to the rear chassis of the instrument.
 - d. While holding the spacer that is between the memory board and rear chassis, pull the screw through the hole in the memory board, and remove the spacer.
 - e. Gently disconnect the A2 Memory Board from the A1 Control Board Assembly.
 - f. Gently pull (toward the front of the instrument) on the CRT shield until the shield disengages from the rear panel.
 - g. Remove the shield by sliding it to the side. You might have to lift up slightly on the rear of the shield while sliding it.
 - h. Disconnect W27 at A1J9.

8. Reconnect the A2 Memory Board Assembly.
9. Reconnect the A5 Power Supply outside of the instrument using the cable extender and the line module/switch assembly from the service kit.
10. Connect the power cord to the line module/switch assembly and set the line switch to ON (|).
11. At A1J18 or A1J19, measure the voltages as indicated in the table. See figure 2-4.

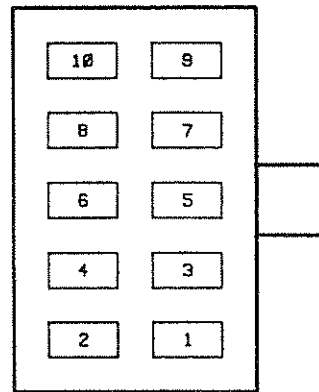

Figure 2-4. A1J18 and A1J19 Pin Identification Drawing

12. Reinstall the assemblies that were removed.

**To Verify the Signals
Between the A6
Baseband Board and
the A1 Control Board**

Refer to Block Diagrams 2, 3, and 7 for the connections to and from the A6 Baseband Boards. If the A6 Baseband Boards and the A1 Control Board are functioning properly together, the following will be measured at the indicated points:

- With a peak power sensor connected to channel 1 or channel 4 and no power applied to the sensor, -200 mV to +100 mV will be input from W21 (CH 4) or W22 (CH 1) into the A6 Baseband Board.
- -450 mV to -300 mV will be input through W14 (CH 1) or W15 (CH 4) into A1J1 or A1J4 on the A1 Control Board.
- Pins 2 and 4 of A1J11 or A1J12 will show TTL activity during a vertical sensitivity change, that is $\geq 20x$ (for example, going from 2 mW/division to 0.1 mW/division).

To gain access to the points mentioned, use the following steps:

1. Set the rear panel line switch to OFF (O).
2. Disconnect the power cord from the line module/switch assembly.
3. Remove six screws from the top and two screws from each side of the Peak Power Analyzer's cabinet with a #10 TORX® screwdriver.

4. Lift the top cover off.
5. With a #10 TORX® screwdriver, remove the cover to the A6 Baseband Boards Housing Assembly.
6. Disconnect the cables to the A6 Baseband Board Assembly.
7. Remove the A6 Baseband Board from the baseband shield.
8. Reconnect the board outside the shield.
9. Connect the power cord to the line module/switch assembly and set the line switch to ON (|).
10. Measure the signal out of W21 or W22 at A6J1.
11. Measure the signal into W14 or W15 at A6J2.
12. Turn the instrument OFF and disconnect the power cord.
13. Disconnect W16 or W17 from the A6 Baseband Assembly. W16 and W17 connect to A1J11 and A1J12 on the A1 Control Board.
14. Connect the power cord to the line module/switch assembly and set the line switch to ON (|).
15. With an oscilloscope, observe the TTL activity on pins 2 and 4 of cables W16 and W17 during a vertical sensitivity change. See figure 2-5.

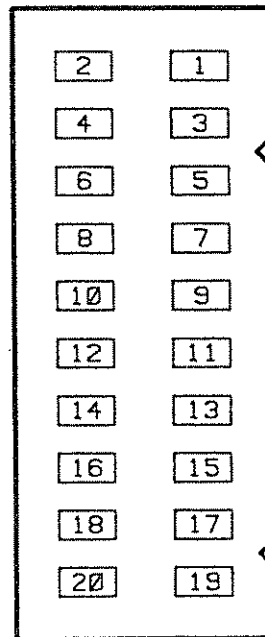
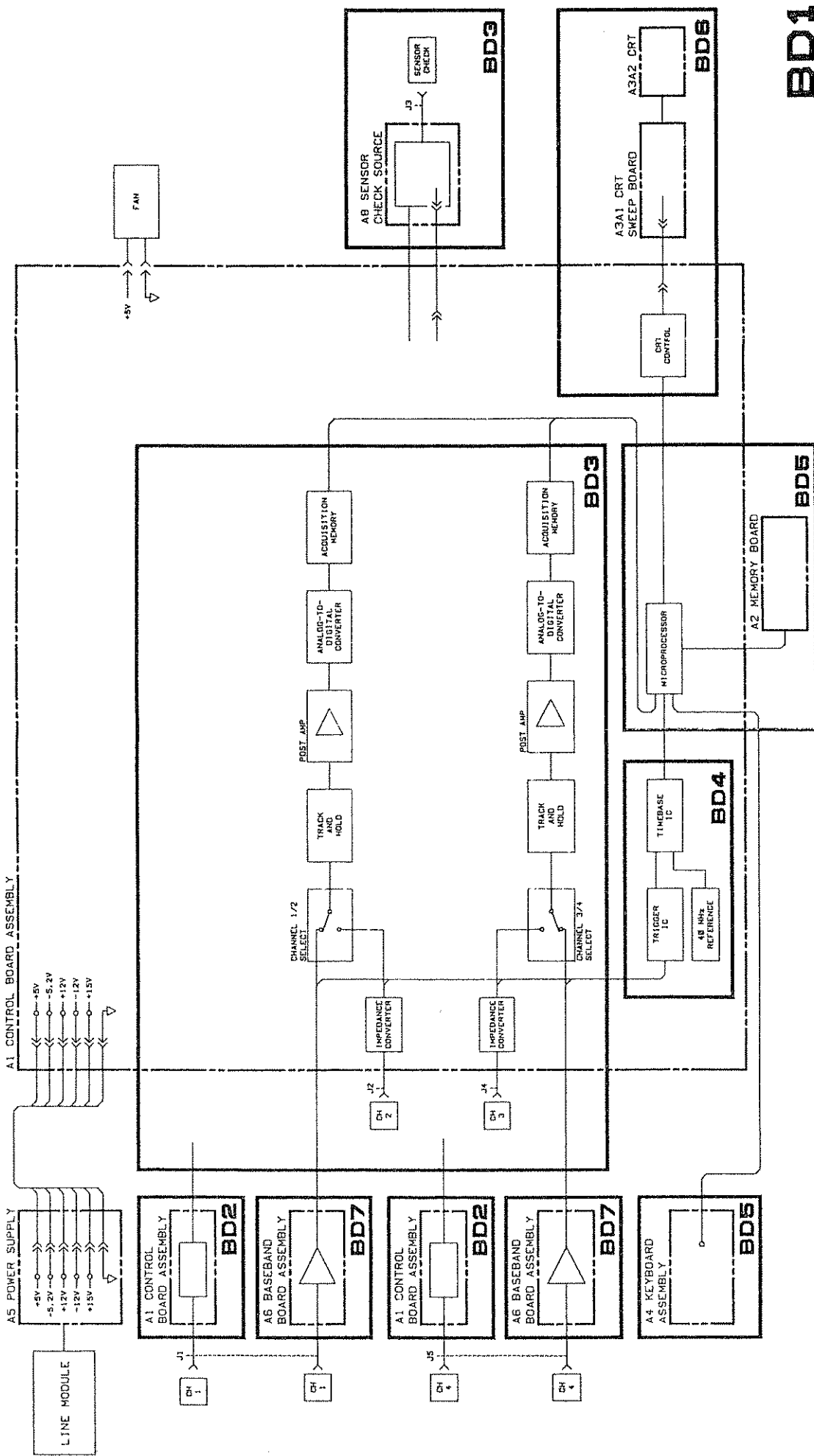

Figure 2-5. Connector for W16 and W17

Turn the instrument OFF and disconnect the power cord. Reconnect the cables, and reassemble the instrument.



BD1

Figure 2-7. Overall Block Diagram
2-21

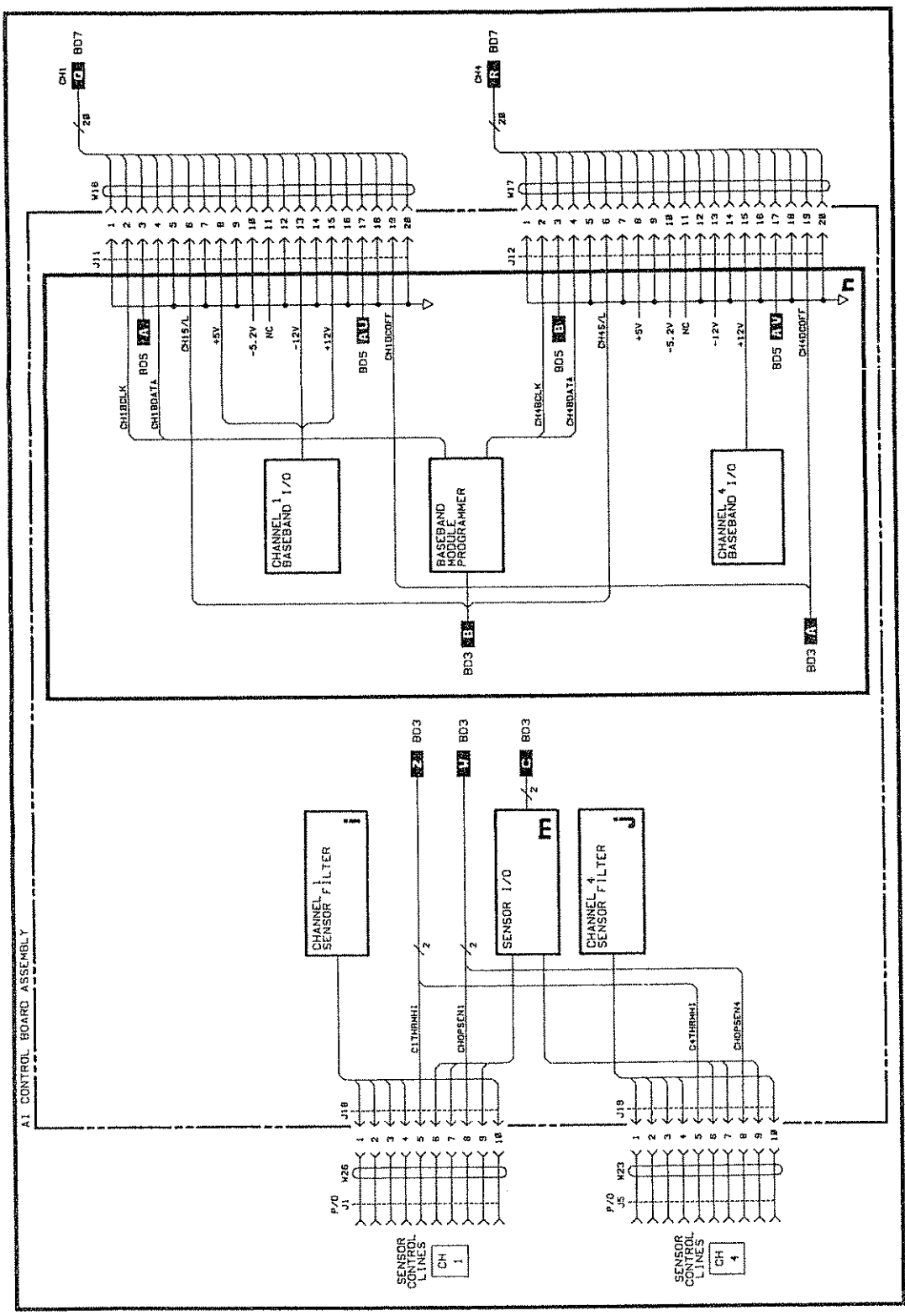

BD2

Figure 2-8. Acquisition Interconnect Block Diagram

1
2
3
4
5
6
7
8
9
10
11
12
13
14
15
16
17
18
19
20
21
22
23
24
25
26
27
28
29
30
31
32
33
34
35
36
37
38
39
40
41
42
43
44
45
46
47
48
49
50
51
52
53
54
55
56
57
58
59
60
61
62
63
64
65
66
67
68
69
70
71
72
73
74
75
76
77
78
79
80
81
82
83
84
85
86
87
88
89
90
91
92
93
94
95
96
97
98
99
100

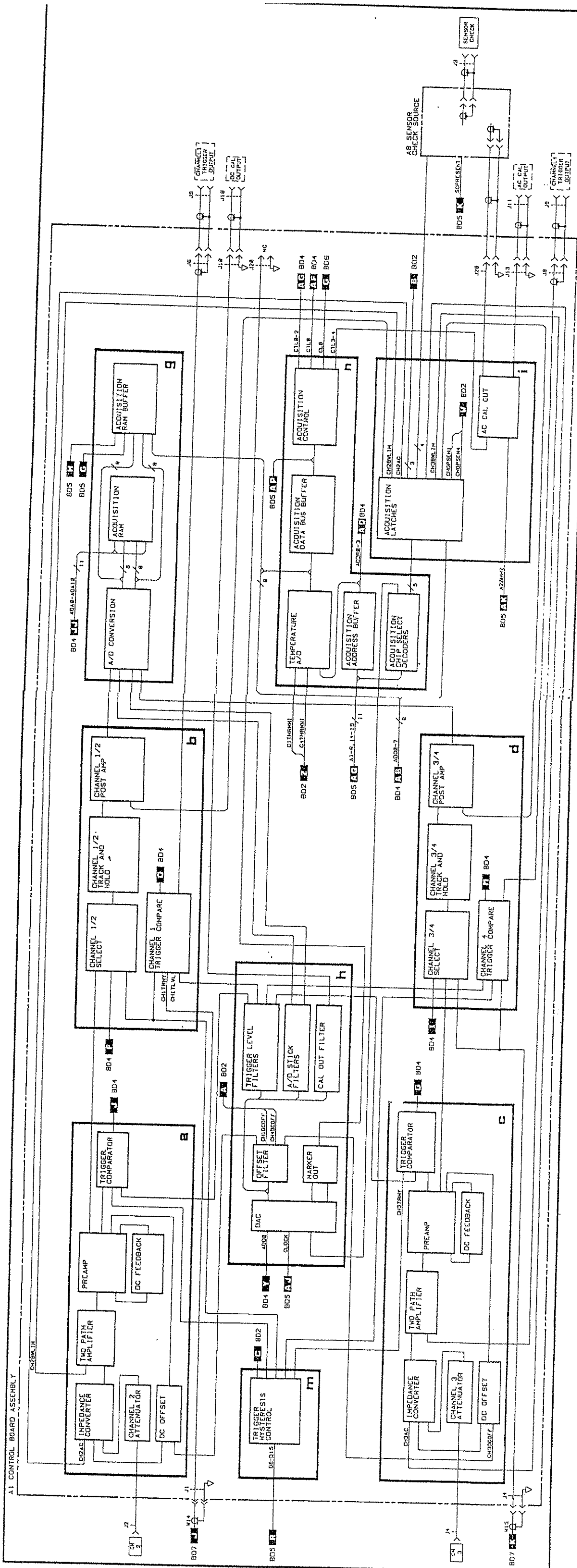

BD3

Figure 2-9. Acquisition Block Diagram
2-25

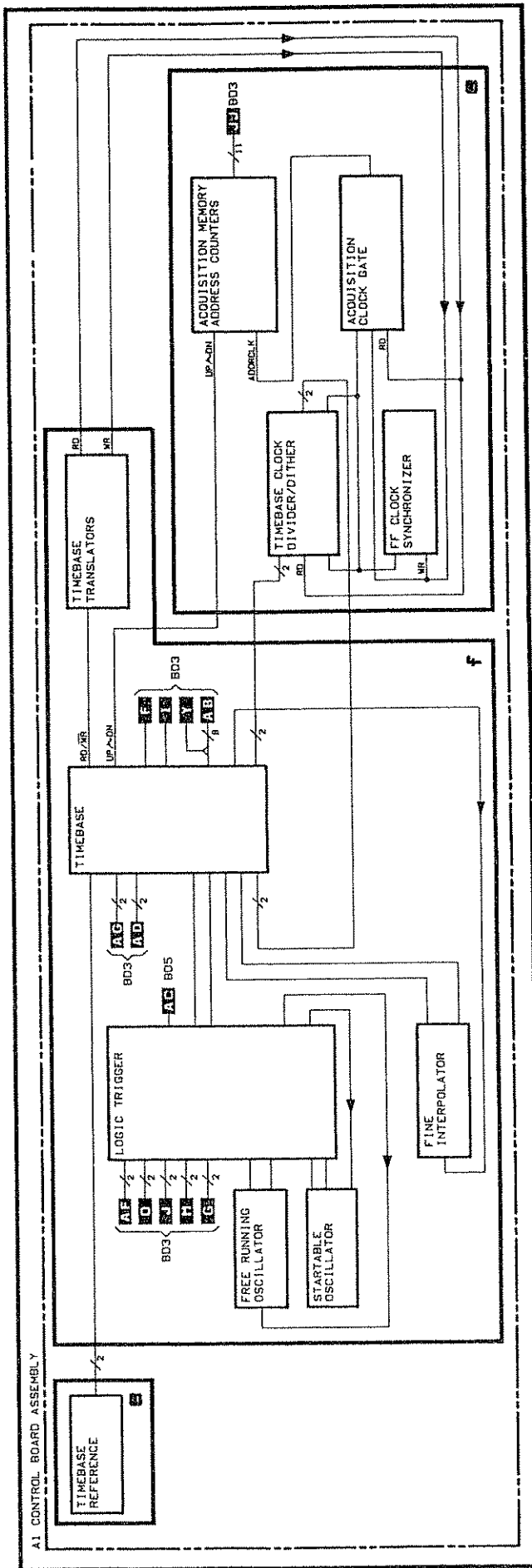

BD4

Figure 2-10. Timebase and Trigger Block Diagram
2-27

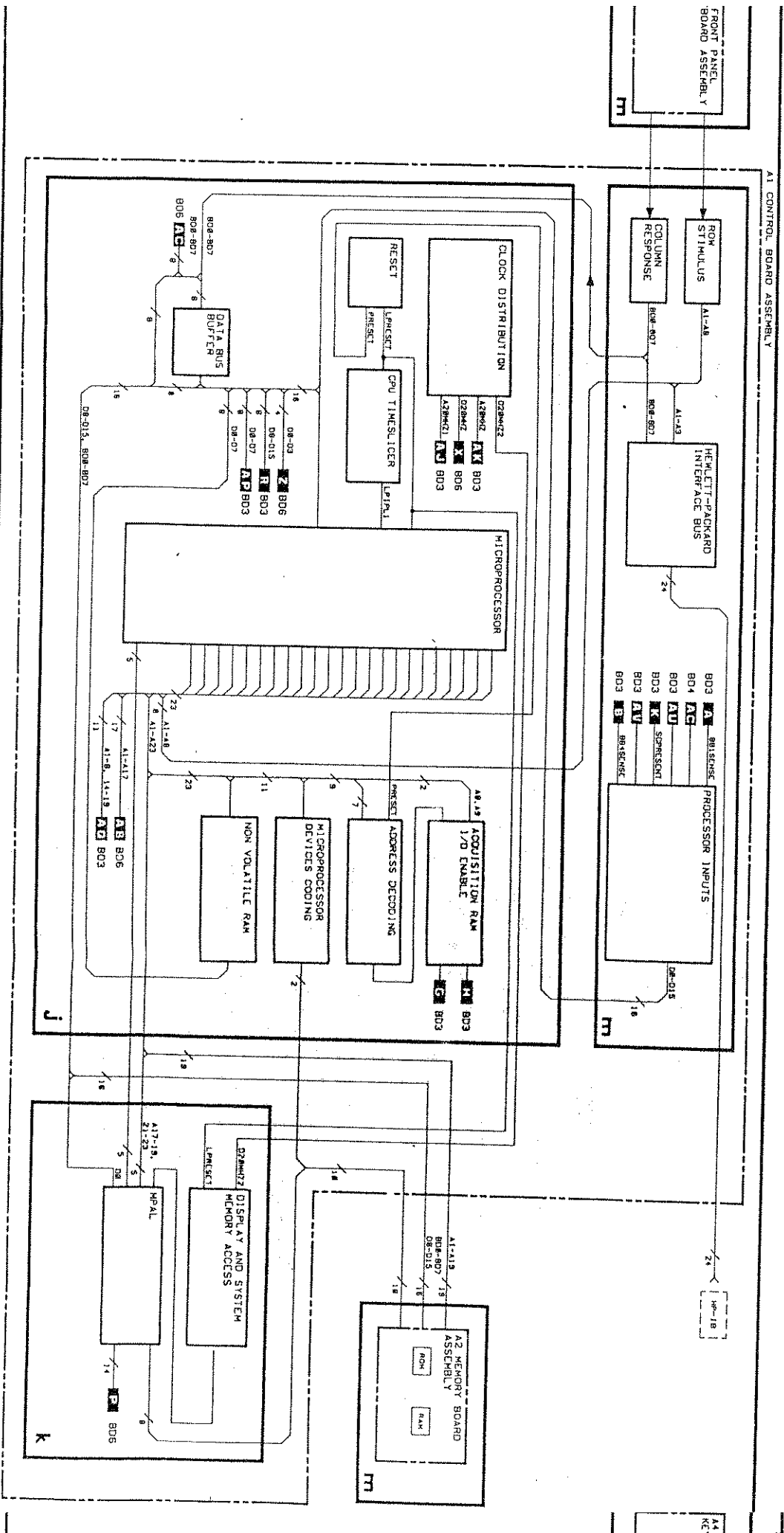
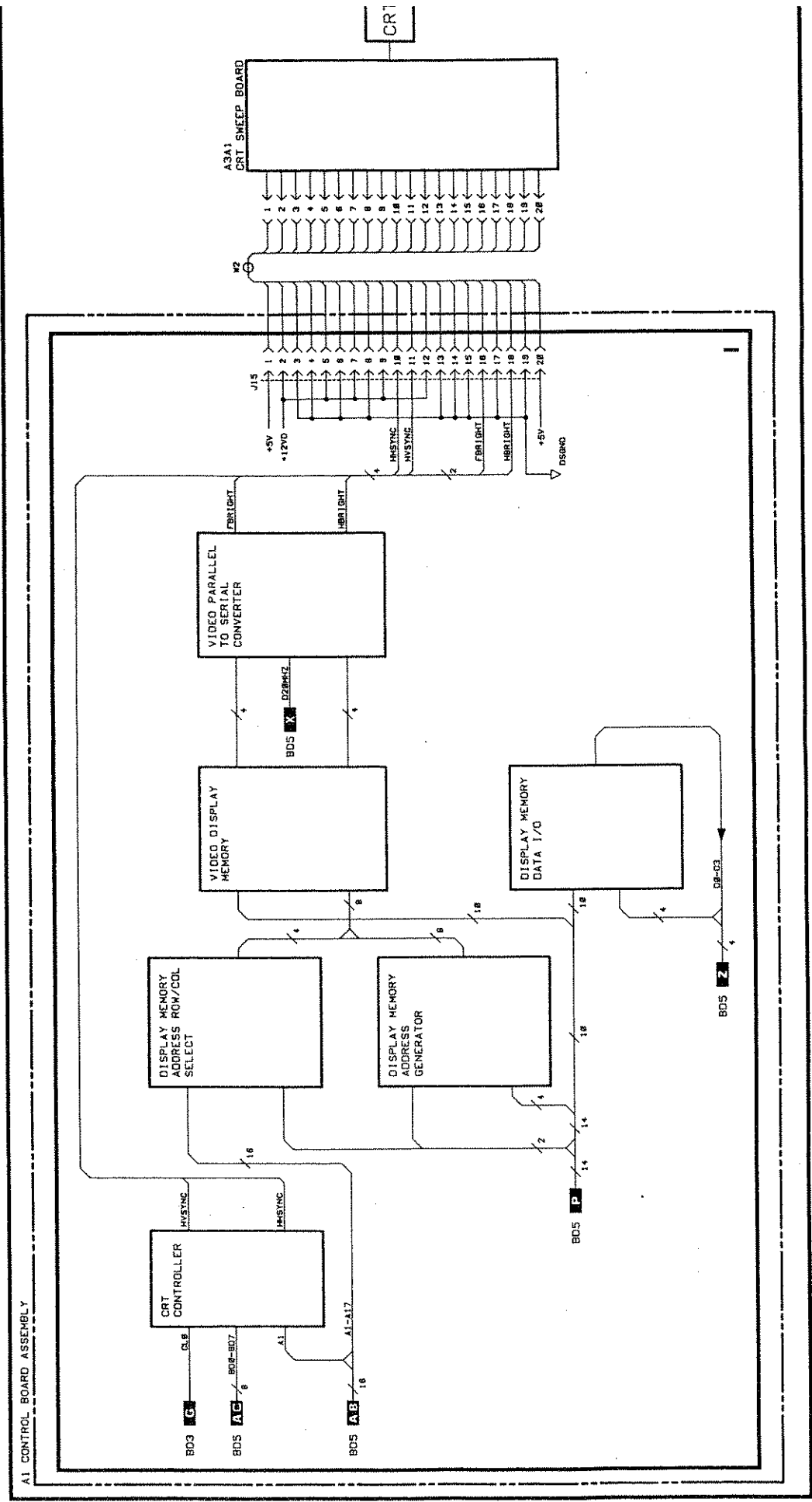
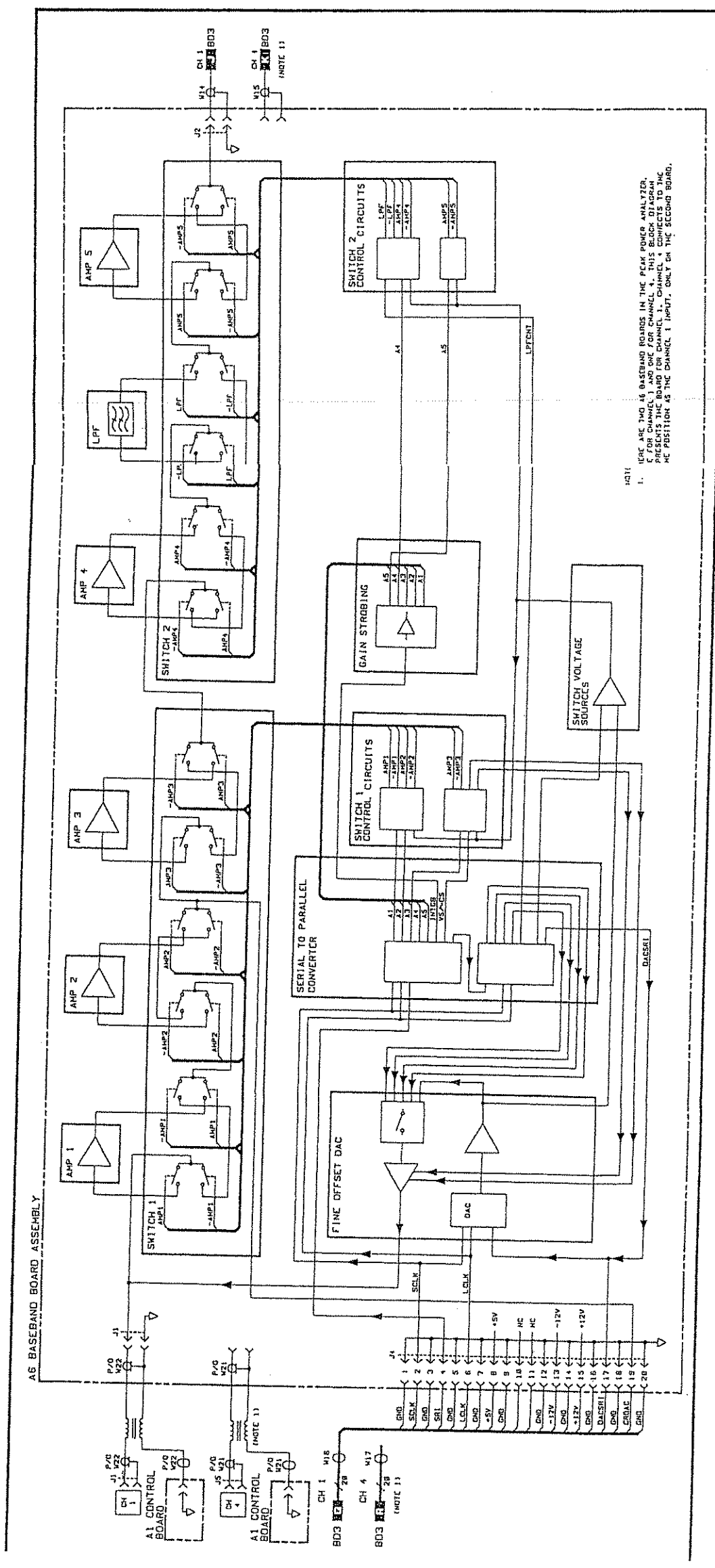

Figure 2-11. Microprocessor Block Diagram

1 2 3 4 5 6 7 8 9 10 11 12 13 14 15 16 17 18 19 20 21 22 23 24 25 26 27 28 29 30 31 32 33 34 35 36 37 38 39 40 41 42 43 44 45 46 47 48 49 50 51 52 53 54 55 56 57 58 59 60 61 62 63 64 65 66 67 68 69 70 71 72 73 74 75 76 77 78 79 80 81 82 83 84 85 86 87 88 89 90 91 92 93 94 95 96 97 98 99 100



BD
Figure 2-12. CRT Control and CRT Block Dia!



NOTE 1:
 HERE ARE TWO BASEBOARD BOARDS IN THE PEAK POWER ANALYZER, ONE FOR CHANNEL 1 AND ONE FOR CHANNEL 4. THIS BLOCK DIAGRAM REPRESENTS THE CHANNEL 1 BOARD. THE CHANNEL 4 BOARD IS IDENTICAL TO THE CHANNEL 1 BOARD, ONLY ON THE SECOND BOARD.

Figure 2-13. Baseband Board Block Diagram
 2-33

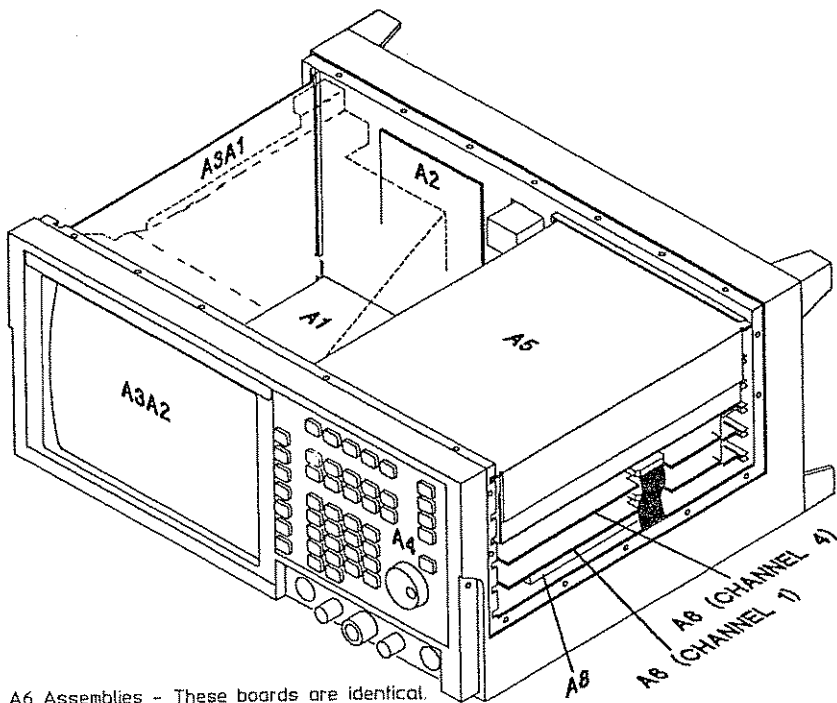

A6 Assemblies - These boards are identical.
A7 designator - not assigned.

Figure 2-14. HP 8990A Peak Power Analyzer Major Assemblies

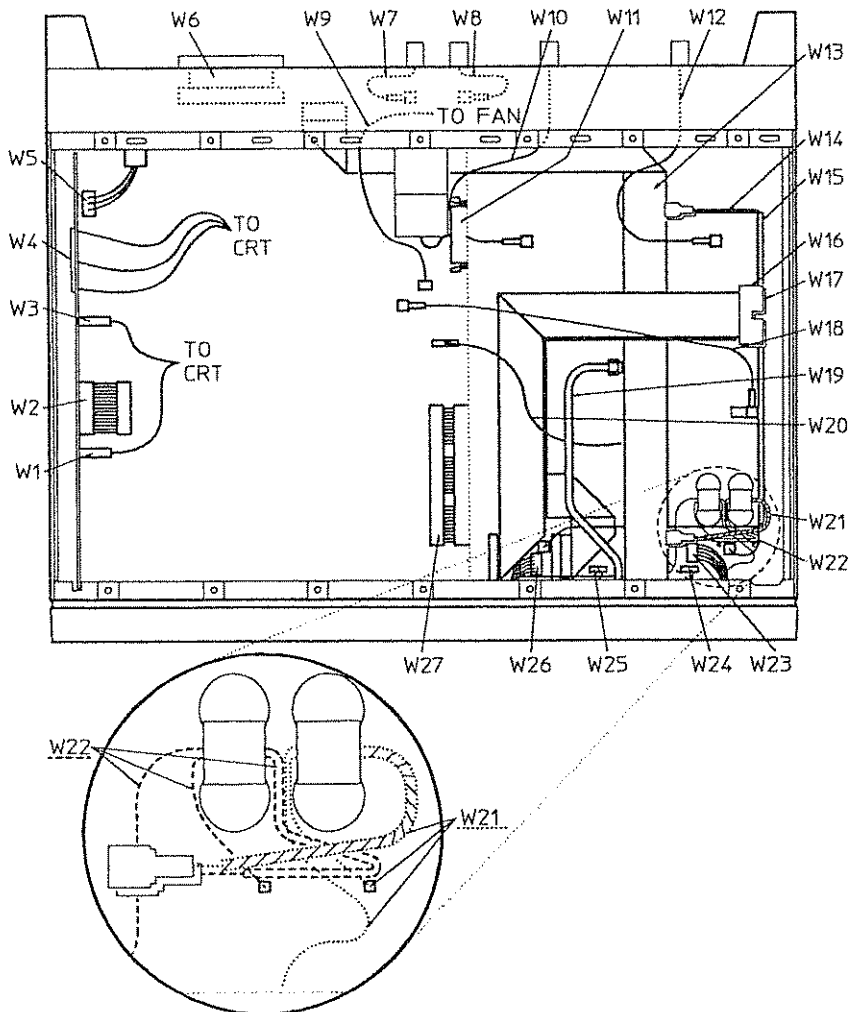

Figure 2-15. HP 8990A Peak Power Analyzer Cable Assemblies

Isolating the Problem

Note



When performing the procedures, it is important that you note how the cable assemblies are dressed (routed) within the Peak Power Analyzer. For example, if cable assemblies W21 and W22 (see figure 2-15 for their location within the instrument) are not dressed properly, low level accuracy can be effected.

Caution



Before continuing, ensure that the line module is set to the available line (mains) voltage. Use the following steps to set the line module:

1. Set the rear panel line switch to OFF (\bigcirc).
 2. Disconnect the power cord from the line module/switch assembly.
 3. Remove the fuse block from the line module/switch assembly. To do this, place the blade of a small screwdriver into the slot that is near the assembly's power cord receptacle and pry the fuse block out of the assembly.
 4. Replace the fuse block into the line module/switch assembly. Depending on the available line (mains) voltage, ensure that the arrow on the fuse block labeled "110 - 120 V \blacktriangledown " or "220 - 240 V \blacktriangledown " lines up with the thick white line on the line module/switch assembly.
-
1. Verify that the rear panel CALIBRATOR switch is in the PROTECTED position. The setting of this switch determines whether the calibration factors in non-volatile RAM are protected or not.
 2. Disconnect sensors and all other cabling from the front panel and rear panel of the Peak Power Analyzer.
 3. Connect the power cord to the line module/switch assembly.
 4. Depress any key on the front panel while setting the instrument's line switch to ON ($|$).
 5. Visually check the instrument fan to see if it is running. If the fan blades are not turning, go to "To Troubleshoot the Fan," in this chapter. If the fan blades are turning, continue with the next step.
 6. Visually inspect the display to see if it is blank or has random graphics. If it is blank, verify that the DISPLAY INTENSITY control, on the rear panel, is not turned down. If that is not the problem, and the display is still blank or has random graphics, go to "To Troubleshoot the Display (CRT)", in this chapter. If the display is not blank or does not have random graphics, continue with "To Use the CRT Selftest."

To Use the CRT Selftest

The following procedure uses the CRT selftest to verify that the display is functioning properly.

1. Press the front panel **UTIL** menu key.
2. Press the **selftest menu** softkey. If the **selftest menu** softkey is not displayed, press the **more** softkey.
3. Press the uppermost softkey until "misc" is highlighted.
4. Press the second softkey from the top until "crt test" is highlighted.
5. Press the **start test** softkey. The display should be as shown in figure 2-16.

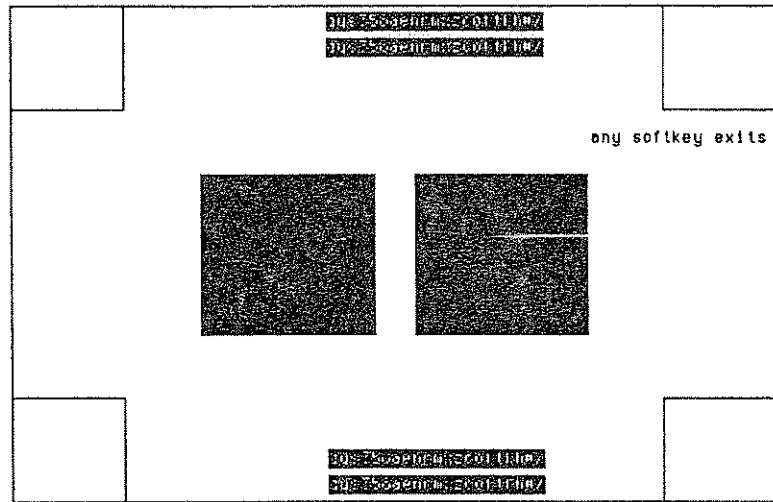

Figure 2-16. Display Selftest

If the display is not as shown in figure 2-16, go to "To Troubleshoot the Display (CRT)." If the display is as shown in figure 2-16, continue with "To Use the Keyboard Selftest."

To Use the Keyboard Selftest

The following procedure uses the keyboard selftest to verify that the front panel keyboard is functioning properly.

1. Press any softkey to exit the display selftest.
2. Press the second softkey from the top until "keyboard" is highlighted.
3. Press the **start test** softkey.
4. Press each front panel key once. As you press each front panel key, you should hear a click, and the text within each key on the display should disappear. When the knob is rotated, a direction indicator should appear on the knob in the display and move in the same direction the knob is being rotated.

If the keyboard selftest does not pass, go to “To Troubleshoot the Keyboard,” in this chapter. If the keyboard selftest passes, continue with “To Verify RF and Video Channel Calibration.”

To Verify RF and Video Channel Calibration

The following procedure uses the built-in calibration feature of the Peak Power Analyzer to isolate a failure to one of the A6 Baseband Boards or the A1 Control Board.

1. Disconnect any peak power sensors connected to the front panel.
2. Perform a vertical calibration of all channels, using the following steps:
 - a. Press the **UTIL** menu key.
 - b. Select the **instr cal menu** softkey. It may be necessary to use the **more** softkey to display the **instr cal menu** softkey.
 - c. Press the top softkey until 0 is displayed and “vertical cal” is highlighted.
 - d. Set the rear panel CALIBRATOR switch to UNPROTECTED.
 - e. Press the **channel** softkey until all is highlighted.
 - f. Press the **start cal** softkey. Follow the displayed instructions.
 - g. Whether a calibration PASSED or FAILED is displayed along the left side of the screen
3. When the calibration is complete, reset the CALIBRATOR switch to PROTECTED.
4. If all the channels passed the vertical calibration, continue with “To Verify the Sensor Check Source.” If channel 1 or 4 failed the calibration, go to “To Troubleshoot a Channel 1 or 4 Calibration Failure,” in this chapter. If channel 2 or 3 failed the calibration, go to “To Troubleshoot a Channel 2 or 3 Calibration Failure,” in this chapter.

To Verify the Sensor Check Source

This procedure is used to verify that the A8 Sensor Check Source is functioning properly. If a problem is identified, it is isolated to the A8 Sensor Check Source or the A1 Control Board.

1. Press the front panel **UTIL** menu key.
2. Press the third softkey from the top until “cw” is highlighted. It may be necessary to press the **more** softkey to display the **check source** softkey.
3. Zero and calibrate a power meter and appropriate power sensor. You will be measuring +10 dBm at 1 GHz.
4. Connect the power meter and sensor to the SENSOR CHECK output on the front panel of the Peak Power Analyzer.

5. Measure the power at the SENSOR CHECK output. The power meter should measure +10 dBm \pm 0.5 dBm.

If the power meter does not measure the correct power, continue with "To Verify the Sensor Check Source is Installed and Connected." If the power meter does measure the correct power, continue with "To Verify the Sensor Check Source Frequency."

To Verify the Sensor Check Source is Installed and Connected

1. Press the **show status** softkey.
2. If "Sensor check source: present" is shown, continue with "To Verify the Sensor Check Source Cabling and Supply Voltage." If "Sensor check source: not found" is shown, continue with the next step and verify that the A8 Sensor Check Source is installed and properly connected.
3. Set the rear panel line switch to OFF ().
4. Disconnect the power cord from the line module/switch assembly.
5. Remove six screws from the top and two screws from each side of the Peak Power Analyzer's cabinet with a #10 TORX® screwdriver.
6. Lift the top cover off.
7. Perform the following procedures in the disassembly chapter of this manual: "To Remove the A5 Power Supply" and "To Remove the A6 Baseband Boards Housing."
8. If the A8 Sensor Check Source is found to be installed and cables W18 and W20 are connected properly, verify the continuity of pins 4 and 5 of cable W20. Black wires are connected to pins 4 and 5. If continuity is bad, replace cable W20. If continuity is good, replace the A1 Control Board Assembly.
9. Reinstall the A5 Power Supply and the A6 Baseband Boards.
10. Measure the power again. The problem should be fixed. There is no need to perform the following steps.

To Verify the Sensor Check Source Cabling and Supply Voltage

1. Set the rear panel line switch to OFF ().
2. Disconnect the power cord from the line module/switch assembly.
3. Remove six screws from the top and two screws from each side of the Peak Power Analyzer's cabinet with a #10 TORX® screwdriver.
4. Lift the top cover off.
5. Perform the following procedures in the disassembly chapter of this manual: "To Remove the A5 Power Supply" and "To Remove the A6 Baseband Boards Housing."
6. Perform the following steps in preparation of reconnecting the power supply outside of the instrument:

- a. Remove the two screws securing the line module/switch to the rear panel.
 - b. Slide the line module/switch halfway out the back panel.
 - c. Loosen the screw that attaches the A2 Memory Board assembly to the rear chassis of the instrument.
 - d. While holding the spacer that is between the memory board and rear chassis, pull the screw through the hole in the memory board, and remove the spacer.
 - e. Gently disconnect the A2 Memory Board from the A1 Control Board Assembly.
 - f. Gently pull (toward the front of the instrument) on the CRT shield until the shield disengages from the rear panel.
 - g. Remove the shield by sliding it to the side. You might have to lift up slightly on the rear of the shield while sliding it.
 - h. Disconnect W27 at A1J9.
7. Reconnect the A2 Memory Board Assembly.
 8. Reconnect the A5 Power Supply outside of the instrument using the cable extender and line module from the service kit.
 9. Reconnect the A2 Memory Board.
 10. Disconnect W20 at A1J21. See figure 2-17.

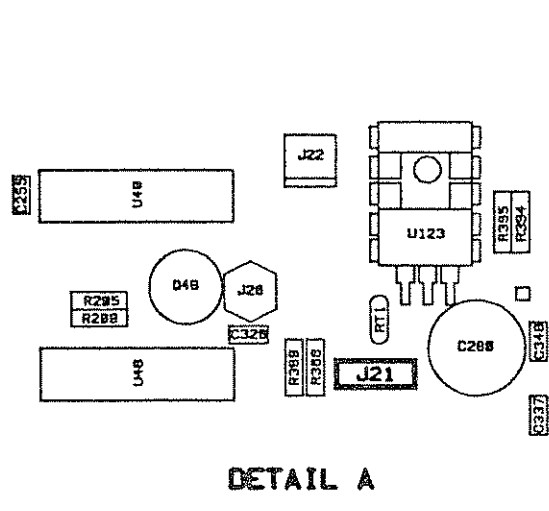
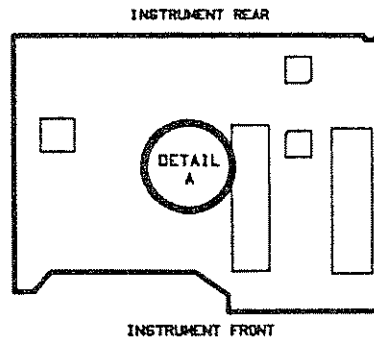

Figure 2-17. Sensor Check Source DC Cable

11. Connect the power cord to the line module/switch assembly and set the line switch to ON (|).
12. Verify that +12 volts is on pin 2 of A1J21. The red wire of W20 connects to pin 2. If the correct voltage is present, continue with the next step. If the voltage is wrong or not present, go to "To Troubleshoot the Power Supply," in this chapter.
13. Set the rear panel line switch to OFF (○).
14. Disconnect the power cord from the line module/switch assembly.
15. Verify that W18 is connected properly and not damaged. If W18 is found to be damaged, replace the cable. If W18 is found to be OK, replace the A8 Sensor Check Source.
16. Repeat the procedure beginning with step 5 of "To Verify the Sensor Check Source." If the problem has been fixed, reinstall the assemblies in the reverse order in which they were removed.

To Verify the Sensor Check Source Frequency

The following steps verify that the A8 Sensor Check Source is producing the specified frequency.

1. Connect a microwave frequency counter to the SENSOR CHECK output on the front panel of the Peak Power Analyzer.
2. Measure the frequency at the SENSOR CHECK output. The frequency counter should measure 1.05 GHz.

If the frequency counter does not measure the correct frequency, replace the A8 Sensor Check Source assembly. If the frequency counter does measure the correct frequency, continue with "To Verify RF Channel Operation."

To Verify RF Channel Operation

This procedure is used to verify that the RF channels (channel 1 and channel 4) are operational. If a problem is found to exist, it is isolated to the A1 Control Board, the A6 Baseband Board, or the peak power sensor.

In the procedure, channel 1 is the channel being verified. But, the procedure applies equally to channel 4.

1. Connect a peak power sensor to channel 1 and the SENSOR CHECK source. The **check source** should still be set to cw.
2. Turn channel 1 on using the following steps:
 - Press the **CHAN/VERT** menu key.
 - Press the top softkey until 1 is highlighted.
 - Press the second softkey until **on** is highlighted.
 - Press the front panel **AUTOSCALE** key.
3. If channel 1 can be turned on, continue with step 14. If channel 1 can't be turned on, and the message "no BaseBand assembly found cannot turn on channel" was displayed, continue with the next step. If the channel cannot be turned on, and the message was not displayed, continue with step 13. If the message "sensor not connected ... cannot turn on channel" was displayed, go to "To Troubleshoot the Peak Power Sensor Input" in this chapter.
4. Set the rear panel line switch to OFF ().
5. Disconnect the power cord from the line module/switch assembly.
6. Remove six screws from the top and two screws from each side of the Peak Power Analyzer's cabinet with a #10 TORX® screwdriver.
7. Lift the top cover off.
8. Remove the two screws attaching the cover to the A6 Baseband Boards Housing.
9. Verify that cable W16 is properly connected to the bottom A6 Baseband Board. If the cable is not connected, connect it now.

Then continue with step 2. If the cable is connected properly, continue with the next step.

10. Verify that pins 1 and 3 of A6J4 are connected together on the A6 Baseband Board. If the pins are not connected together, replace the A6 Baseband Board. If the pins are connected together, continue with the next step.
11. Check the continuity of W16. If the cable is bad, replace the cable and continue with the next step. Otherwise, replace the A1 Control Board Assembly and continue with the next step.
12. Reinstall the assemblies that were removed and repeat the procedure beginning with step 2.
13. Move the peak power sensor to channel 4, and turn that channel on. If channel 4 can be turned on, go to "To Verify Operation of the Peak Power Sensor Input," in this chapter, to troubleshoot channel 1. If channel 4 cannot be turned on, the peak power sensor is probably bad. Try another sensor, and continue with the step 2.
14. Use the following steps to verify that the measured peak power is $+10 \text{ dBm} \pm 0.5 \text{ dBm}$:
 - Press the Shift (Blue) key.
 - Press **PEAK** (7) key.
 - Press 1 when C# appears in the lower portion of the display. If C# is not displayed, turn the knob until it is displayed.
15. The measured peak power is now displayed where C# had appeared. If the measured power is $+10 \text{ dBm} \pm 0.5 \text{ dBm}$, continue with the next step. If the power is not as indicated, go to "To Verify Operation of the Peak Power Sensor Input," in this chapter.
16. Press the **UTIL** menu key.
17. Press the **check source** softkey until **pulse** is highlighted.
18. Press the **AUTOSCALE** key. Autoscale takes a few seconds to complete. A pulsed signal should now be displayed.
19. Use the following steps to measure the PRF (Pulse Repetition Frequency) of the displayed waveform:
 - Press the Shift (Blue) key.
 - Press **PRF** (6) key.
 - Press 1 when C# appears in the lower portion of the display.
20. If the measured PRF is 1.5 kHz, continue with "To Verify Triggering." If the PRF is not 1.5 kHz, continue with the next step.

21. Perform the following procedures in the disassembly chapter of this manual: "To Remove the A5 Power Supply", "To Remove the A6 Baseband Boards Housing."
22. Disconnect W18 at A1J28 on the A1 Control Board. See figure 2-18.

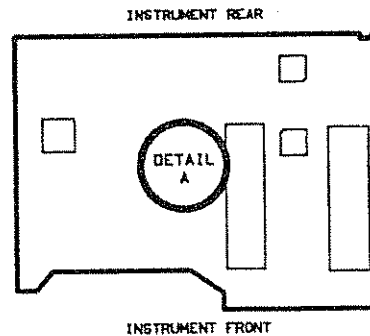

Figure 2-18. Sensor Check Source Modulation Cable

23. Perform the following steps in preparation to connecting the power supply outside of the instrument:
 - a. Remove the two screws securing the line module/switch to the rear panel.
 - b. Slide the line module/switch halfway out the back panel.
 - c. Loosen the screw that attaches the A2 Memory Board assembly to the rear chassis of the instrument.
 - d. While holding the spacer that is between the memory board and rear chassis, pull the screw through the hole in the memory board, and remove the spacer.
 - e. Gently disconnect the A2 Memory Board from the A1 Control Board Assembly.

- f. Gently pull (toward the front of the instrument) on the CRT shield until the shield disengages from the rear panel.
 - g. Remove the shield by sliding it to the side. You might have to lift up slightly on the rear of the shield while sliding it.
 - h. Disconnect W27 at A1J9.
24. Reconnect the A2 Memory Board Assembly.
 25. Reconnect the A5 Power Supply outside of the instrument using the cable extender and the line module/switch assembly from the service kit.
 26. Connect the power cord to the line module/switch assembly and set the line switch to ON (|).
 27. Use an oscilloscope to measure the signal a A1J28. The signal will be ECL with a PRF of 1.5 kHz. If the signal is as stated, continue with the next step. If the signal is not as stated, replace the A1 Control Board and repeat the procedure beginning with step 19.
 28. Verify that W18 is not damaged. If W18 is damaged, replace the cable. If the cable is found to be OK, replace the A8 Sensor Check Source. In either case, reinstall the assemblies that were removed, and repeat the procedure beginning with step 19.

To Verify Triggering

With the following procedure the ability of the Peak Power Analyzer to trigger using an external trigger is verified.

1. Connect the rear panel AC CAL output to channel 2 (CH2) on the front panel.
2. Use the following steps to select channel 2 as the trigger:
 - Press the **TRIG** menu key.
 - Press **source** until 2 is highlighted.
 - Press the **level** softkey. Adjust the level with the knob if necessary to get a stable waveform.
3. If the waveform is stable, continue with step 12. If the waveform is unstable, continue with the next step.
4. Set the rear panel line switch to OFF (O).
5. Disconnect the power cord from the line module/switch assembly.
6. Remove six screws from the top and two screws from each side of the Peak Power Analyzer's cabinet with a #10 TORX® screwdriver.
7. Lift the top cover off.
8. Perform the following procedures in the disassembly chapter of this manual: "To Remove the A5 Power Supply", "To Remove

the A6 Baseband Boards Housing”, and “To Remove the A8 Sensor Check Source Assembly.”

9. Check the AC CAL and channel 2 BNC connectors. Replace the connectors if necessary. If the connectors seem OK, replace the A1 Control Board Assembly.
10. Repeat the procedure starting with step 1, and reinstall the assemblies that were removed.
11. Disconnect the AC CAL signal from channel 2, and connect it to channel 3.
12. Set the trigger source to channel 3 by using the **TRIG** menu.
13. Verify a stable waveform as with channel 2.
14. Reset the trigger source back to channel 1.

To Run the Selftests

This procedure describes how to use the Peak Power Analyzer's selftests. The selftests are used to decide if a problem exists with the A1 Control Board.

1. Disconnect all inputs and outputs to and from the front and rear panels.
2. Press the front panel **UTIL** key on the instrument.
3. Press the **selftest menu** softkey. It may be necessary to press the **more** softkey to display the **selftest menu**.
4. Press the **test all** softkey. The instrument now performs a full set of selftests. These selftests take approximately forty seconds to run.
5. Verify that all selftests pass. The results displayed on the screen should be as follows:

Note



The “D/A Converter” test will always fail for instruments that have the single channel option (Option 001) installed.

```

PASSED System RAM
PASSED Non-Volatile RAM
PASSED Display RAM
PASSED Protected Non-Volatile RAM
PASSED System ROM
PASSED Acquisition RAM
PASSED Logic Trigger
PASSED Timebase
PASSED D/A Converter
PASSED HPIB
PASSED A/D Converter

```

If any selftests fail, “FAILED” will replace “PASSED” in the results.

6. If any selftests fail, replace the A1 Control Board assembly. If all selftests pass, continue with "To Troubleshoot the Peak Power Sensor Input."

To Troubleshoot the Peak Power Sensor Input

The following procedure is used to isolate a problem to the peak power sensor or the A1 Control Board.

1. Set the rear panel line switch to OFF ().
2. Disconnect the power cord from the line module/switch assembly.
3. Remove six screws from the top and two screws from each side of the Peak Power Analyzer's cabinet with a #10 TORX® screwdriver.
4. Lift the top cover off.
5. Perform the following procedures in the disassembly chapter of this manual: "To Remove the A5 Power Supply", "To Remove the A6 Baseband Boards Housing", and "To Remove the A8 Sensor Check Source Assembly."
6. Depending on the channel in question, disconnect the cable at A1J18 (W26; CH 1) or A1J19 (W23; CH 4) on the A1 Control Board. See figure 2-19.

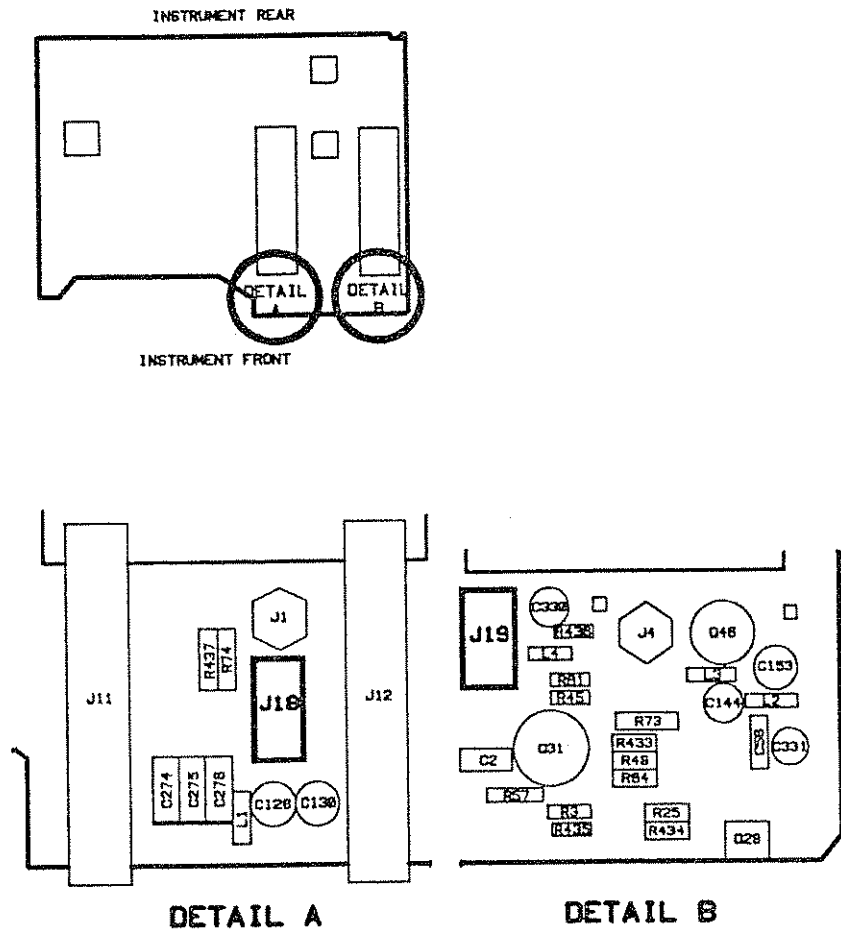

Figure 2-19. Channel 1 and Channel 4 DC Cable Locations

7. Perform the following steps in preparation to connecting the power supply outside the instrument:
 - a. Remove the two screws securing the line module/switch to the rear panel.
 - b. Slide the line module/switch halfway out the back panel.
 - c. Loosen the screw that attaches the A2 Memory Board assembly to the rear chassis of the instrument.
 - d. While holding the spacer that is between the memory board and rear chassis, pull the screw through the hole in the memory board, and remove the spacer.
 - e. Gently disconnect the A2 Memory Board from the A1 Control Board Assembly.
 - f. Gently pull (toward the front of the instrument) on the CRT shield until the shield disengages from the rear panel.
 - g. Remove the shield by sliding it to the side. You might have to lift up slightly on the rear of the shield while sliding it.
 - h. Disconnect W27 at A1J9.

8. Reconnect the A2 Memory Board Assembly.
9. Reconnect the A5 Power Supply outside the instrument using the cable extender and the line module/switch assembly from the service kit.
10. Connect the power cord to the line module/switch assembly and set the line switch to ON (|).
11. At A1J18 or A1J19, measure the voltages on the following pins: Pin 1, -12 volts; Pin 2, -5.2 volts; Pin 3, +5.8 volts, and Pin 4, +12 volts. See figure 2-20. The voltages should be approximately as shown. If the voltages are correct, continue with the next step. If the voltages are wrong, replace the A1 Control Board Assembly.

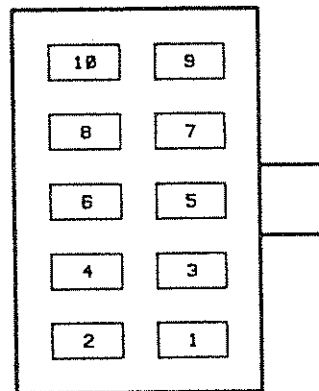

Figure 2-20. A1J18 and A1J19 Pin Identification Drawing

12. Verify the voltages again with a resistive load. Use a 5 k Ω resistor for the 5 volt supplies and a 12 k Ω resistor for the 12 volt supplies. If the voltages are no longer correct, replace the A1 Control Board. If the voltages are still correct, the peak power sensor is bad.
13. Reinstall the assemblies that were removed.

To Troubleshoot a Channel 2 or 3 Calibration Failure

The following procedure is used to isolate the cause of a channel 2 or channel 3 vertical calibration failure.

1. Set the rear panel line switch to OFF (\bigcirc).
2. Disconnect the power cord from the line module/switch assembly.
3. Remove six screws from the top and two screws from each side of the Peak Power Analyzer's cabinet with a #10 TORX® screwdriver.
4. Lift the top cover off.
5. Perform the following procedures in the disassembly chapter of this manual: "To Remove the A5 Power Supply", "To Remove the A6 Baseband Boards Housing", and "To Remove the A8 Sensor Check Source Assembly."
6. Verify that the following connector/cables are connected properly and are not damaged: J2 (W25; CH2), J4 (W24; CH3), and J10 (W8; DC CAL). Take the appropriate action required if any of the connectors are found not to be connected properly or are damaged. Then run the vertical calibration again. If the connector/cables are found to be OK, replace the A1 Control Board. Run the vertical calibration again.
7. Replace the assemblies that were removed.

To Troubleshoot a Channel 1 or 4 Calibration Failure

Use the following procedure to isolate a channel 1 or channel 4 vertical calibration failure to the A1 Control Board, the A6 Baseband Board, or the cabling.

1. If one channel is failing, continue with the next step. If both channels are failing, perform steps 2 through 5 and continue with step 10.
2. Set the rear panel line switch to OFF (\bigcirc), and disconnect the power cord from the line module/switch assembly.
3. Remove six screws from the top and two screws from each side of the Peak Power Analyzer's cabinet with a #10 TORX® screwdriver.
4. Lift the top cover off.
5. With a #10 TORX® screwdriver, remove the cover to the A6 Baseband Boards Housing Assembly. See figure 2-21.

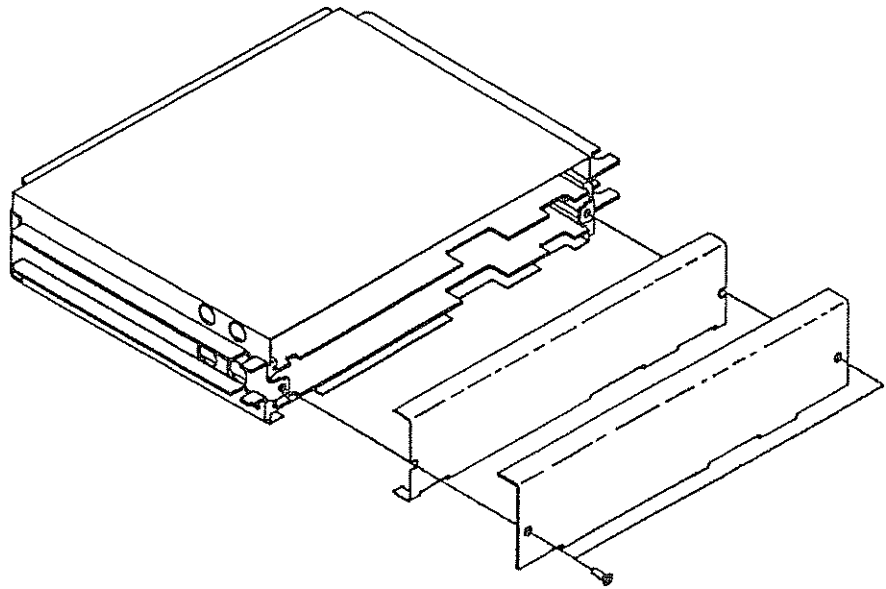

Figure 2-21. A6 Baseband Covers

6. Disconnect the coaxial and ribbon cables to the two boards. Note where to reconnect the cables.
7. Swap the boards and reconnect the cables.
8. Perform a vertical calibration again. If the other channel is failing now, replace the A6 Baseband Board. If the other channel did not fail, check the condition of the cabling and replace if necessary. If the cabling is OK, replace the A1 Control Board.
If the calibration passed, check the cabling and connections to the A6 assembly. Swap the A6 assemblies again.
9. Perform a vertical calibration again. If both channels pass, the problem has been solved. If the channel fails again, replace the failing A6 assembly and associated cabling. Do not continue, you are done.
10. If both channels 1 and 4 have failed the vertical calibration, verify that the cabling to the A6 Baseband Boards is correct. The top baseband board is for channel 4 and the bottom board is for channel 1. The following cables connect to the top board: W15, W17, and W21. The following cables connect to the bottom board: W14, W16, and W22.
11. If the cabling is incorrect, make the proper connections, and repeat the vertical calibration. If the cabling is correct, continue with the next step.

12. Were the diagnostic words (1s and 0s) the same for each channel? If the words are the same, replace the A1 Control Board Assembly. If the words are different, continue with the next step.
13. Swap the A6 Baseband Boards, and repeat the vertical calibration.
14. If the channel 1 and 4 diagnostic words stayed the same, replace the A1 Control Board. If the diagnostic words followed the A6 Baseband Boards, replace both A6 Baseband Boards. If the diagnostic words are different but new, repeat the procedure starting at step 10. If the same thing happens the second time through, replace both A6 Baseband Boards.
15. Repeat the vertical calibration procedure. If the calibration passes, the problem is fixed. If the calibration fails again, replace the assembly, either the A1 Control Board or the A6 Baseband Board, that has not been replaced.

To Troubleshoot the Fan

Since you are using this procedure, it is assumed the fan is not functioning.

The following procedure will isolate a fan problem to the fan, the cabling, the line module, the A5 Power Supply, or the A1 Control Board.

To Check the Fan Mechanically

1. Set the rear panel line switch to OFF () and then disconnect the power cord from the line module/switch assembly.
2. Remove six screws from the top and two screws from each side of the Peak Power Analyzer's cabinet with a #10 TORX® screwdriver.
3. Lift the top cover off.
4. In the disassembly chapter of this manual, perform the procedure "To Remove the Rear Panel Assembly." But, there is no need to disconnect the coaxial or ribbon cables.
5. Spin the fan by hand to see if it is mechanically stuck. If the fan won't spin, replace it. If the fan does spin, continue with the next step.
6. Replace the rear panel, and continue with "To Check the Configuration of the Line Module."

To Check the Configuration of the Line Module

1. Verify that the line module/switch is configured correctly for the available line voltage. If it is configured correctly, go to "Checking the Line Module Output Voltage." If it is not configured correctly, continue with the next step.
2. Remove the fuse block from the line module/switch assembly. To do this, place the blade of a small screwdriver into the slot that is near the assembly's power cord receptacle and pry the fuse block out of the assembly (see figure 2-22).

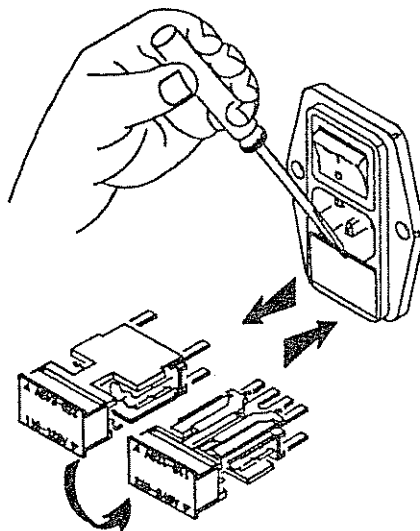

Figure 2-22. Fuse Block Removal

3. Remove the fuse from the fuse block by prying it out with a small blade screwdriver.
4. Check the continuity of the fuse. If the fuse is opened, replace the fuse with a 3 A, 250 V fuse. If the fuse is not opened, return it to the fuse block and continue with the next step.
5. Replace the fuse block into the line module/switch assembly. Depending on the available line (mains) voltage, ensure that the arrow on the fuse block labeled "110 - 120 V ▼" or "220 - 240 V ▼" lines up with the thick white line on the line module/switch assembly.
6. Plug the power cord into the line module/switch assembly.
7. Set the line switch to ON (|). If the fan begins to function, the procedure is complete. If the fan still fails to function, continue with the next step.
8. Set the rear panel line switch to OFF (○) and disconnect the power cord from the line module/switch assembly.
9. Check the fuse again. If the fuse is OK, continue with "To Check the Line Module Output Voltage." If the fuse was blown, go to "To Troubleshoot a Bad Fuse," in this chapter.

To Check the Line Module Output Voltage

1. Set the rear panel line switch to OFF (\bigcirc) and then disconnect the power cord from the line module/switch assembly.
2. Disconnect the cable (W11) from the line module to the A5 Power Supply.
3. Connect the power cord to the line module/switch assembly and set the line switch to ON ($\big|$).
4. Measure the voltages out of the line module at the end of cable W11. The voltages should be as shown in table 2-2. The pin numbers are on the backside of the connector. If the voltages are not correct, replace the line module. If the voltages are correct, continue with the next step.

Table 2-2. Line Module Output Voltages

Line Voltage	Pin	Voltage
110 to 120	1	110 to 120
	2	Neutral
	3	(NC)
	4	(NC)
220 to 240	1	220 to 240
	2	Neutral
	3	(NC)
	4	(NC)

With the power disconnected and using an ohm-meter, the resistance for pins 3 and 4 should read zero for 110-120 Vac voltage setting, and ∞ (open) for 220-240 Vac voltage setting.

To Check the Cabling

1. Set the rear panel line switch to OFF (\bigcirc) and then disconnect the power cord from the line module/switch assembly.
2. Reconnect the cable (W11) between the A5 Power Supply and the line module/switch assembly.
3. Verify that the following cables are seated properly:
 - a. W11 from the line module to the A5 Power Supply
 - b. W27 from the A5 Power Supply to the A1 Control Board
 - c. W9 from the A1 Control Board to the Fan.
4. Connect any cables that are loose.
5. Connect the power cord to the line module/switch assembly and set the line switch to ON ($\big|$).
6. If the fan is now functioning, the problem has been solved. If the fan is still not functioning, continue with "To Measure the Fan Voltage."

To Measure the Fan Voltage

1. Set the rear panel line switch to OFF () and disconnect the power cord from the line module/switch assembly.
2. In the disassembly chapter of this manual, perform the following procedures: "To Remove the A5 Power Supply", "To Remove the A6 Baseband Boards Housing", and "To Remove the Rear Panel Assembly."
3. Perform the following steps in preparation of connecting the power supply outside of the instrument:
 - a. Remove the two screws securing the line module/switch to the rear panel.
 - b. Slide the line module/switch halfway out the back panel.
 - c. Loosen the screw that attaches the A2 Memory Board assembly to the rear chassis of the instrument.
 - d. While holding the spacer that is between the memory board and rear chassis, pull the screw through the hole in the memory board, and remove the spacer.
 - e. Gently disconnect the A2 Memory Board from the A1 Control Board Assembly.
 - f. Gently pull (toward the front of the instrument) on the CRT shield until the shield disengages from the rear panel.
 - g. Remove the shield by sliding it to the side. You might have to lift up slightly on the rear of the shield while sliding it.
 - h. Disconnect W27 at A1J9.
4. Reconnect the A2 Memory Board Assembly.
5. Reconnect the power supply outside of the instrument using the cable extender and line module/switch assembly from the service kit.
6. Disconnect the cable (W9) at A1J22 on the A1 Control Board Assembly.
7. Connect the power cord to the line module/switch assembly and set the line switch to ON ().
8. Measure the voltage on A1J22-pin 1. If the measured voltage is greater than 5 volts, replace the fan. Otherwise, turn the instrument OFF and reconnect W9. Continue with "To Measure the Power Supply Voltages."

To Measure the Power Supply Voltages

1. Next to where cable W27 connects to the A5 Power Supply, measure the voltage on each pin. See figure 2-23. The voltages should be as shown in figure 2-23. If any of the voltages are wrong, replace the A5 Power Supply. If the voltages are correct, replace cable W27.
2. The fan should be operating properly now.
3. Reinstall the assemblies that were removed.

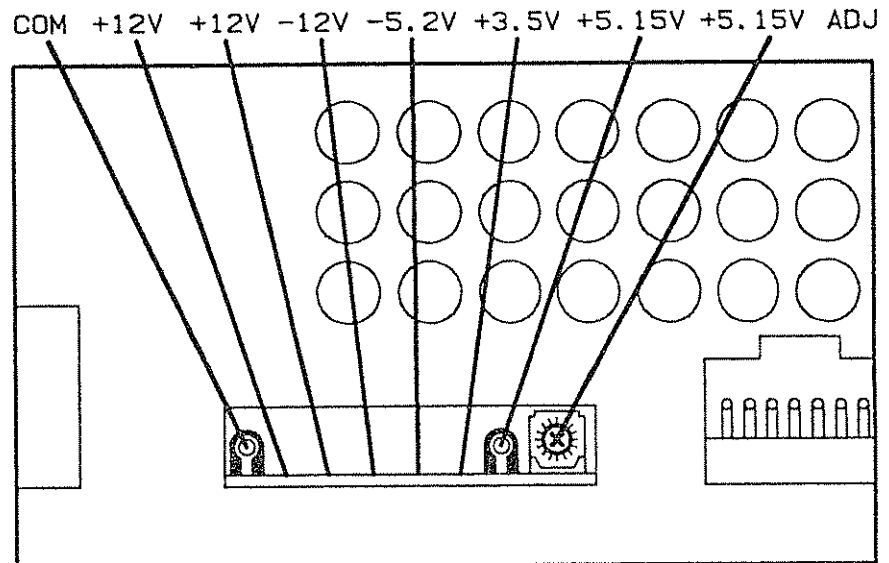

Figure 2-23. A5 Power Supply Test Points

To Troubleshoot the Power Supply

This procedure will isolate a power supply problem to the cabling, the power supply fuse, the line module, or the A5 Power Supply.

To Check the Cabling and Power Supply Fuse

1. Set the rear panel line switch to OFF (\bigcirc) and then disconnect the power cord from the line module/switch assembly.
2. Remove six screws from the top and two screws from each side of the Peak Power Analyzer's cabinet with a #10 TORX[®] screwdriver.
3. Lift the top cover off.
4. Verify that the cable (W27) from the A5 Power Supply to the A1 Control Board Assembly is connected properly. If it is connected properly, continue with the next step. Otherwise, reconnect the cable.
5. Set the instrument line switch to OFF (\bigcirc) and disconnect the power cord from the line module/switch assembly .

6. Remove the A5 Power Supply Assembly from the instrument. Refer to "To Remove the A5 Power Supply Assembly" in the disassembly chapter of this manual.
7. Remove the power supply fuse from the power supply assembly. The fuse, labeled F1, is at the opened end of the power supply assembly chassis.
8. Check the continuity of the fuse. If the fuse is opened, replace the fuse with a 5 A, 250 V fuse. If the fuse is not opened, replace it and continue with the next step.
9. Reinstall the A5 Power Supply Assembly. Reverse the procedure for removing the assembly.

To Check the Line Module Voltage

1. Set the rear panel line switch to OFF () and disconnect the power cord from the line module/switch assembly.
2. Disconnect the cable (W11) from the line module to the A5 Power Supply.
3. Connect the power cord to the line module/switch assembly and set the line switch to ON ().
4. Measure the voltages out of the line module at the end of cable W11. The voltages should be as shown in table 2-3. The pins are identified on the backside of the connector. If the voltages are not correct, replace the line module. If the voltages are correct, continue with the next step.

Table 2-3. Line Module Output Voltages

Line Voltage	Pin	Voltage
110 to 120	1	110 to 120
	2	Neutral
	3	(NC)
	4	(NC)
220 to 240	1	220 to 240
	2	Neutral
	3	(NC)
	4	(NC)

With the power disconnected and using an ohm-meter, the resistance for pins 3 and 4 should read zero for 110-120 Vac voltage setting, and ∞ (open) for 220-240 Vac voltage setting.

**To Check the Power
Supply Voltages**

1. Set the rear panel line switch to OFF () and disconnect the power cord from the line module/switch assembly.
2. Remove the A5 Power Supply Assembly from the instrument. Refer to "To Remove the A5 Power Supply Assembly" in the disassembly chapter of this manual.
3. Perform the following steps in preparation of reconnecting the power supply outside of the instrument:
 - a. Remove the two screws securing the line module/switch to the rear panel.
 - b. Slide the line module/switch halfway out the back panel.
 - c. Loosen the screw that attaches the A2 Memory Board assembly to the rear chassis of the instrument.
 - d. While holding the spacer that is between the memory board and rear chassis, pull the screw through the hole in the memory board, and remove the spacer.
 - e. Gently disconnect the A2 Memory Board from the A1 Control Board Assembly.
 - f. Gently pull (toward the front of the instrument) on the CRT shield until the shield disengages from the rear panel.
 - g. Remove the shield by sliding it to the side. You might have to lift up slightly on the rear of the shield while sliding it.
 - h. Disconnect W27 at A1J9.
4. Reconnect the A2 Memory Board Assembly.
5. Reconnect the A5 Power Supply outside of the instrument using the cable extender and line module/switch supplied with the service kit.
6. Connect the power cord to the line module/switch assembly and set the line switch to ON ().
7. Measure the power supply voltages on the A5 Power Supply next to where W27 connects to the power supply. See figure 2-24.

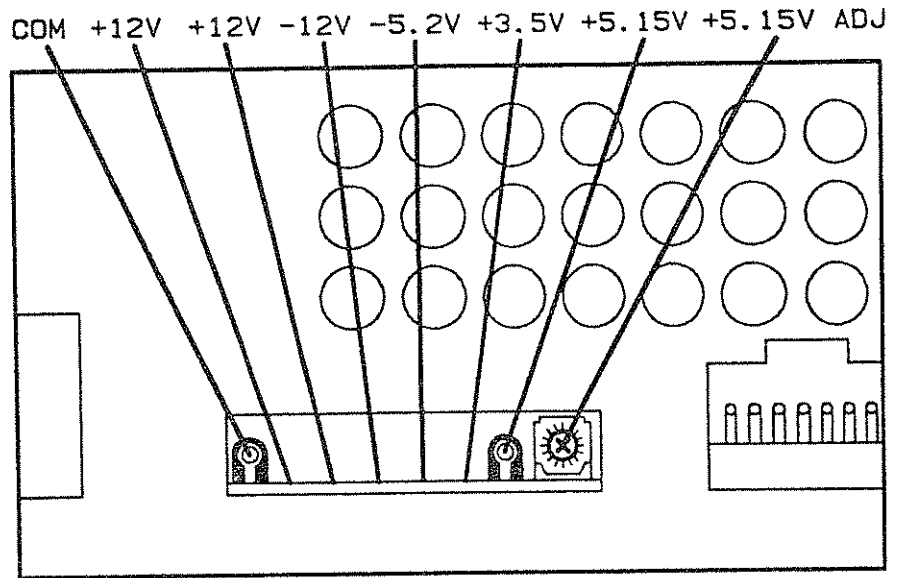

Figure 2-24. A5 Power Supply Test Points

8. If all power supply voltages are as shown in figure 2-24, continue with the next step. If any of the voltages are not as shown, replace the A5 Power Supply.
9. Set the rear panel line switch to OFF (\bigcirc) and then disconnect the power cord from the line module/switch assembly.
10. Check the continuity of all conductors of the power cable (W27). If some conductors are open, replace the power cable (W27).
11. Reinstall the assemblies that were removed.

To Troubleshoot a Bad Fuse

Since you are using this procedure, it is assumed that one of the assemblies is causing the line fuse to blow. The following procedure is designed to systemically remove each of the assemblies in order to locate the assembly causing the problem

1. Set the rear panel line switch to OFF (\bigcirc) and disconnect the power cord from the line module/switch assembly.
2. Remove six screws from the top and two screws from each side of the Peak Power Analyzer's cabinet with a #10 TORX® screwdriver.
3. Perform the following disassembly procedures in the Disassembly Chapter of this manual: "To Remove the A5 Power Supply" and "To Remove the A6 Baseband Boards Housing."
4. Disconnect cable W2 at the A3A1 CRT Sweep Board Assembly.

5. Disconnect the A2 Memory Board Assembly. Remove the screw at the top of the assembly, and rock the assembly side to side to loosen it.
6. Replace the A5 Power Supply and the A6 Baseband Boards Housing. Reverse the disassembly procedures to install the assemblies. Do not connect the ribbon cables to the A6 Baseband Boards.
7. Replace the blown fuse.
8. Remove the fuse block from the line module/switch assembly. To do this, place the blade of a small screwdriver into the slot that is near the assembly's power cord receptacle and pry the fuse block out of the assembly (see figure 2-25).

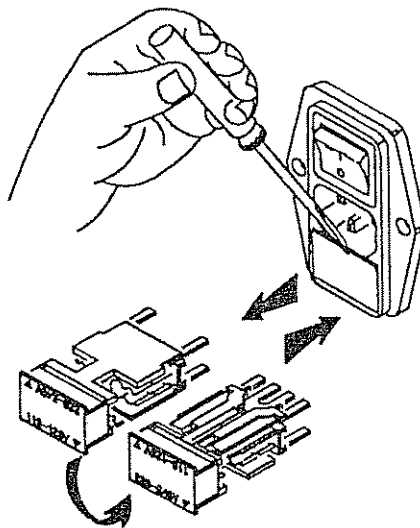

Figure 2-25. Fuse Block Removal

9. Remove the fuse from the fuse block by prying it out with a small blade screwdriver.
10. Place a new fuse in the fuse block.
11. Replace the fuse block into the line module/switch assembly. Depending on the available line (mains) voltage, ensure that the arrow on the fuse block labeled "110 - 120 V ▼" or "220 - 240 V ▼" lines up with the thick line on the line module/switch assembly.
12. Connect the power cord to the line module/switch assembly and set the line switch to ON (|).
13. If the fuse does not blow again, the problem is with an assembly that was removed or disconnected. If the fuse does blow again, continue with step 15.
14. Reconnect the assemblies one at a time to figure out the assembly causing the problem, and replace the defective

- assembly. Continue with the next step only if the problem has not been located.
15. Set the rear panel line switch to OFF (O) and disconnect the power cord from the line module/switch assembly.
 16. Remove the A5 Power Supply and A6 Baseband Board Assemblies again.
 17. Reconnect the assemblies and cables that were previously disconnected.
 18. Disconnect the following cables at the A1 Control Board Assembly: W9, W13, and W20.
 19. Perform the following steps in preparation of reconnecting the power supply outside the instrument:
 - a. Remove the two screws securing the line module/switch to the rear panel.
 - b. Slide the line module/switch halfway out the back panel.
 - c. Loosen the screw that attaches the A2 Memory Board assembly to the rear chassis of the instrument.
 - d. While holding the spacer that is between the memory board and rear chassis, pull the screw through the hole in the memory board, and remove the spacer.
 - e. Gently disconnect the A2 Memory Board from the A1 Control Board Assembly.
 - f. Gently pull (toward the front of the instrument) on the CRT shield until the shield disengages from the rear panel.
 - g. Remove the shield by sliding it to the side. You might have to lift up slightly on the rear of the shield while sliding it.
 - h. Disconnect W27 at A1J9.
 20. Reconnect the A2 Memory Board Assembly.
 21. Reconnect the A5 Power Supply outside the instrument using the cable extender and line module/switch assembly supplied with the service kit.
 22. Reconnect the A6 Baseband Board Assembly without installing it in the Peak Power Analyzer.
 23. Replace the blown fuse.
 24. Connect the power cord to the line module/switch assembly and set the line switch to ON (|).
 25. Reconnect the cables one at a time to figure out the assembly causing the problem, and replace the defective assembly. If the problem continues, the problem is with the A1 Control Board or the A5 Power Supply.

26. If another A5 Power Supply is available, swap it with the power supply currently being used. If the problem is fixed, replace the A5 Power Supply. Otherwise replace the A1 Control Board Assembly.
27. Reconnect the cables that were disconnected. Reinstall the A5 Power Supply and the A6 Baseband Boards Housing Assembly.
28. Replace the instrument cover.

To Troubleshoot the Microprocessor on the A1 Control Board Assembly

Since you are using this procedure, it is assumed that the microprocessor on the A1 Control Board may be causing a problem.

The following steps will help to isolate a microprocessor problem to the A1 Control Board, the A5 Power Supply, or the A2 Memory Board.

1. Set the rear panel line switch to OFF () and disconnect the power cord from the line module/switch assembly.
2. Remove six screws from the top and two screws from each side of the Peak Power Analyzer's cabinet with a #10 TORX® screwdriver.
3. Lift the cover off.
4. Perform the following disassembly procedures in the disassembly chapter of this manual: "To Remove the A5 Power Supply" and "To Remove the A6 Baseband Boards Housing."
5. Perform the following steps in preparation of reconnecting the power supply outside of the instrument:
 - a. Remove the two screws securing the line module/switch to the rear panel.
 - b. Slide the line module/switch halfway out the back panel.
 - c. Loosen the screw that attaches the A2 Memory Board assembly to the rear chassis of the instrument.
 - d. While holding the spacer that is between the memory board and rear chassis, pull the screw through the hole in the memory board, and remove the spacer.
 - e. Gently disconnect the A2 Memory Board from the A1 Control Board Assembly.
 - f. Gently pull (toward the front of the instrument) on the CRT shield until the shield disengages from the rear panel.
 - g. Remove the shield by sliding it to the side. You might have to lift up slightly on the rear of the shield while sliding it.
 - h. Disconnect W27 at A1J9.
6. Reconnect the A2 Memory Board Assembly.

7. Reconnect the A5 Power Supply outside of the Peak Power Analyzer using the cable extender and line module/switch assembly supplied with the service kit.
8. Connect the power cord to the line module/switch assembly and set the line switch to ON (|).
9. Check the +5 volt supply on the A5 Power Supply next to where W27 connects to the supply. See figure 2-26. If +5 volts is present, continue with the next step. If +5 volts is not present, continue with step 12.

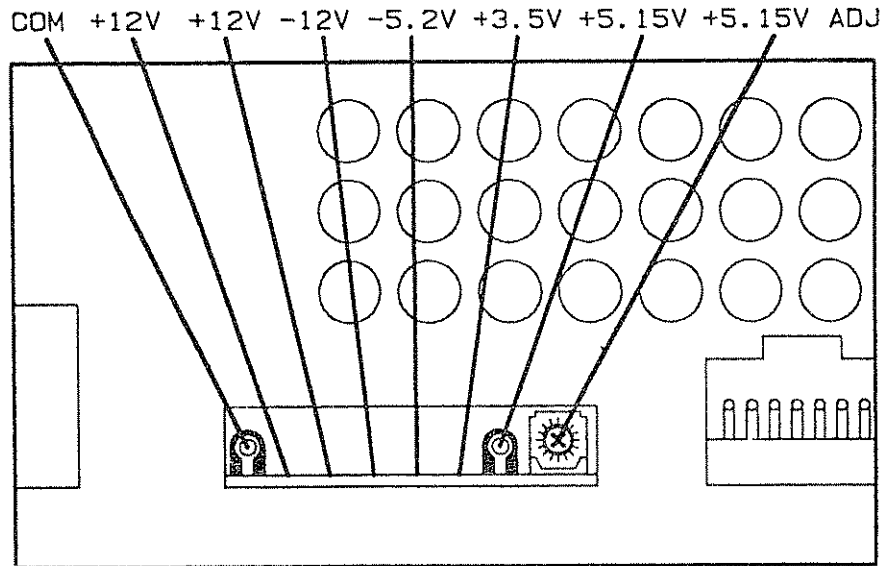

Figure 2-26. A5 Power Supply Test Points

10. Set the rear panel line switch to OFF (O) and disconnect the power cord from the line module/switch assembly.
11. Check the continuity of power cable W27. If the cable is OK, continue with step 13. If the cable is found to be defective, replace the cable. The problem should be fixed.
12. Go to "To Troubleshoot a Bad Fuse", in this chapter. Another assembly is shorting the five volt supply. Replace the offending assembly. At this point the five volt supply problem should have been located.
13. Verify that U2 and U3 on the A2 Memory Board Assembly are seated properly. If they are seated properly, continue with the next step. If they are not seated properly, seat the components properly in the board.
14. Replace the A2 Memory Board.
15. Reconnect the power cord to the line module/switch assembly.

16. While holding down one of the front panel keys, turn the instrument ON.
17. Press the SHOW key. If a click is heard, the problem was located on the A2 Memory Board. If a click was not heard, continue with the next step.
18. The problem is on the A1 Control Board. Replace the Control Board.
19. Replace the assemblies that were removed.

To Troubleshoot the Display (CRT)

Since you are using this procedure, it is assumed that there is a problem with the display (CRT).

Use the following procedure to isolate the problem to the cabling, the A1 Control Board, the A5 Power Supply, or the CRT Monitor Assembly.

1. Verify that the rear panel DISPLAY INTENSITY is not set to minimum. If the display intensity is set to minimum, increase the intensity. If the display intensity is OK, continue with the next step.
2. Is a clicking sound coming from the Peak Power Analyzer? If you hear a clicking sound, go to "To Troubleshoot a Bad Fuse", in this chapter. Otherwise, continue with the next step.
3. Set the rear panel line switch to OFF () and disconnect the power cord from the line module/switch assembly.
4. Remove six screws from the top and two screws from each side of the Peak Power Analyzer's cabinet with a #10 TORX® screwdriver.
5. Lift the cover off.
6. Perform the following procedures in the disassembly chapter: "To Remove the A5 Power Supply", "To Remove the A6 Baseband Boards Housing", and "To Remove the Rear Panel Assembly."
7. Perform the following steps in preparation of reconnecting the power supply outside the instrument:
 - a. Remove the two screws securing the line module/switch to the rear panel.
 - b. Slide the line module/switch halfway out the back panel.
 - c. Loosen the screw that attaches the A2 Memory Board assembly to the rear chassis of the instrument.
 - d. While holding the spacer that is between the memory board and rear chassis, pull the screw through the hole in the memory board, and remove the spacer.

- e. Gently disconnect the A2 Memory Board from the A1 Control Board Assembly.
 - f. Gently pull (toward the front of the instrument) on the CRT shield until the shield disengages from the rear panel.
 - g. Remove the shield by sliding it to the side. You might have to lift up slightly on the rear of the shield while sliding it.
 - h. Disconnect W27 at A1J9.
8. Reconnect the A2 Memory Board Assembly.
 9. Connect the A5 Power Supply outside the instrument using the cable extender and line module/switch assembly supplied with the service kit.
 10. Connect the power cord to the line module/switch assembly and set the line switch to ON (|).
 11. If the CRT problem seems gone, the problem may have been with cable W27 that was replaced with the cable extender. If the problem still exists, continue with the next step.
 12. Next to the position where cable W27 connects to the A5 Power Supply, measure the voltage on each pin. See figure 2-27. The voltages should be as shown in figure 2-27. If any of the voltages are wrong, go to "To Troubleshoot the Power Supply," in this chapter. If the voltages are correct, continue with the next step.

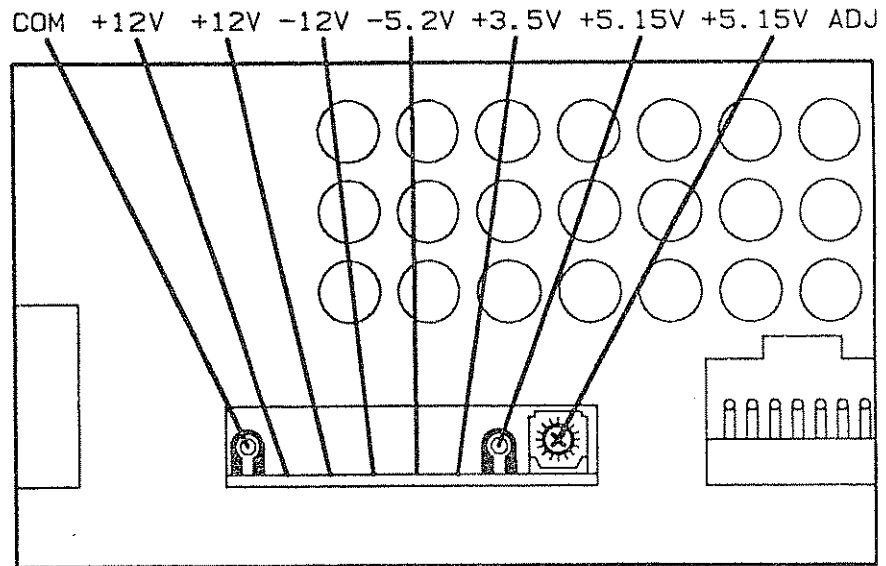

Figure 2-27. A5 Power Supply Test Points

13. Press the front panel SHOW key repeatedly. If a click is not heard, go to "To Troubleshoot the Microprocessor," in this chapter. If a click is heard, continue with the next step.

14. Verify that all cables to the A3A1 CRT Sweep Board are connected securely. If the cables are not securely connected, connect them. If the cables are secure, continue with the next step.
15. Set the rear panel line switch to OFF (\bigcirc) and disconnect the power cord from the line module/switch assembly.
16. Disconnect the CRT sweep cable (W2) from the A3A1 CRT sweep assembly. The CRT sweep cable is the gray ribbon cable that connects near the top of the CRT sweep assembly.
17. Check the voltages and signals on each pin of the CRT sweep cable connector. The voltages and signals should be within the limits shown in table 2-4.

Table 2-4. CRT Sweep Cable Voltages and Signals

Pin	Voltage or Signal	Pin	Voltage or Signal
1	+5 V (Digital)	11	VSYNC ¹
2	+12 V (Display)	12	+12 V (Display)
3	Ground (Display)	13	Ground (Digital)
4	Ground (Display)	14	Ground (Digital)
5	+12 V (Display)	15	Ground (Display)
6	Ground (Display)	16	FB ¹
7	+12 V (Display)	17	Ground (Display)
8	Ground (Display)	18	HB ¹
9	+12 V (Display)	19	Ground (Display)
10	HSYNC ¹	20	+5 V (Digital)

¹These signals are dynamic digital signals. Check for activity on these pins with an oscilloscope.

18. If all voltages and signals are within the specified limits, replace the CRT monitor assembly. If some or all voltages and signals are not within the specified limits, continue with the next step.
19. Check the continuity of all conductors of the CRT sweep cable. If all conductors show continuity from pin to pin, replace the A1 Control Board Assembly. If some conductors are open, replace the CRT sweep cable.
20. Replace the assemblies that were removed.

To Troubleshoot the Keyboard

It is assumed that since you are using this procedure there may be a keyboard problem. If you were directed here from the section "To Use the Keyboard Selftest," begin with step 7. If your troubleshooting began with this section, start with step 1.

1. Press the front panel **UTIL** key on the instrument.
2. Press the **selftest menu** softkey. It may be necessary to press the **more** softkey to display the **selftest menu** softkey.
3. Press the uppermost softkey until "misc" is highlighted.
4. Press the second softkey from the top until "keyboard" is highlighted.
5. Press the **start test** softkey.
6. Press each front panel key once. As you press each front panel key, you should hear a click and the text within each key on the display should disappear. Also, when the knob is rotated, a direction indicator should appear on the knob in the display and move in the same direction the knob is being rotated. If some, but not all keys (or the knob) are responding, note those keys that are not responding and continue with "To Troubleshoot the Keypad," in this chapter. If the keyboard is totally not functioning, continue with the next step.
7. Set the rear panel line switch to OFF () and disconnect the power cord from the line module/switch assembly.
8. Remove six screws from the top and two screws from each side of the Peak Power Analyzer's cabinet with a #10 TORX® screwdriver.
9. Lift the top cover off.
10. Perform the following procedures in the disassembly chapter of this manual: "To Remove the A5 Power Supply", "To Remove the A6 Baseband Boards Housing", and "To Remove the A8 Sensor Check Source Assembly."
11. Perform the following steps in preparation of reconnecting the power supply outside the instrument:
 - a. Remove the two screws securing the line module/switch to the rear panel.
 - b. Slide the line module/switch halfway out the back panel.
 - c. Loosen the screw that attaches the A2 Memory Board assembly to the rear chassis of the instrument.
 - d. While holding the spacer that is between the memory board and rear chassis, pull the screw through the hole in the memory board, and remove the spacer.

- e. Gently disconnect the A2 Memory Board from the A1 Control Board Assembly.
 - f. Gently pull (toward the front of the instrument) on the CRT shield until the shield disengages from the rear panel.
 - g. Remove the shield by sliding it to the side. You might have to lift up slightly on the rear of the shield while sliding it.
 - h. Disconnect W27 at A1J9.
12. Reconnect the A2 Memory Board Assembly.
 13. Reconnect the A5 Power Supply outside the instrument using the cable extender and line module/switch assembly supplied with the service kit.
 14. Connect the power cord to the line module/switch assembly and set the line switch to ON (|).
 15. Run the keyboard test again. If the test passes, power cable W27 was more than likely bad. Replace the cable. If the test still fails, continue with the next step.
 16. Next to the position where cable W27 connects to the A5 Power Supply, measure the voltage on each pin. See figure 2-28. The voltages should be as shown in figure 2-28. If any of the voltages are not as shown, go to "To Troubleshoot the Power Supply," in this chapter. If the voltages are as shown, continue with the next step.

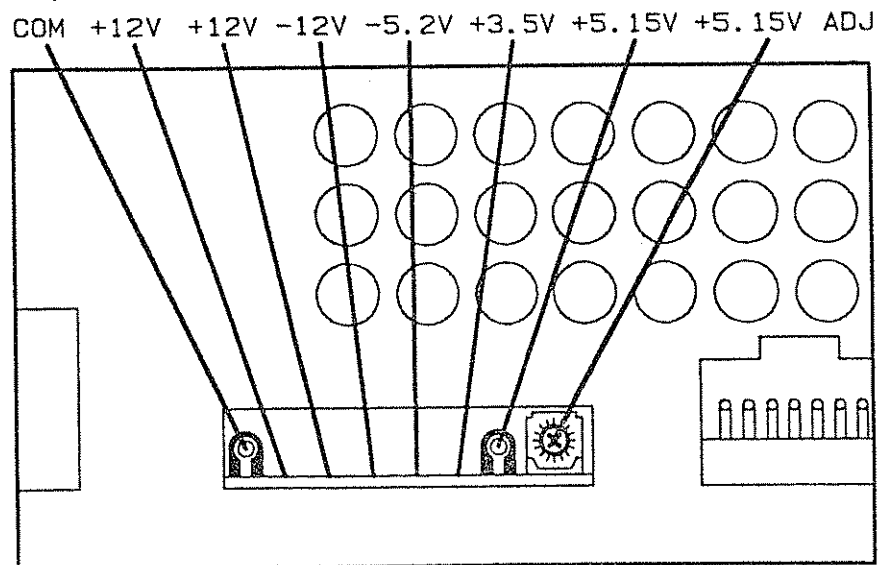

Figure 2-28. A5 Power Supply Test Points

17. Set the rear panel line switch to OFF (O) and disconnect the power cord from the line module/switch assembly.

18. Perform the following procedure in the disassembly chapter of this manual: "To Remove the A4 Keyboard Assembly."
19. Check the continuity of the keyboard cable from connector to connector. Note that this cable does not detach from the printed circuit keyboard. You must check continuity at the point where the cable is soldered to the board.
20. If all conductors of the keyboard cable show continuity from connector to connector, replace the A1 Control Board Assembly. If some conductors do not show continuity, replace the keyboard assembly. At this point the problem should have been fixed. There is no need to continue.

To Troubleshoot the Keypad

Following this procedure is "To Troubleshoot the Rotary Pulse Generator (RPG)." If a problem exists with the RPG, perform steps 1 through 13 of this procedure. Then, go to "To Troubleshoot the Rotary Pulse Generator (RPG)."

1. Set the rear panel line switch to OFF (\bigcirc) and disconnect the power cord from the line module/switch assembly.
2. Remove six screws from the top and two screws from each side of the Peak Power Analyzer's cabinet with a #10 TORX[®] screwdriver.
3. Lift the top cover off.
4. Perform the following procedures in the disassembly chapter of this manual: "To Remove the A5 Power Supply", "To Remove the A6 Baseband Boards Housing", and "To Remove the A8 Sensor Check Source Assembly"
5. Perform the following steps in preparation of connecting the power supply outside of the instrument:
 - a. Remove the two screws securing the line module/switch to the rear panel.
 - b. Slide the line module/switch halfway out the back panel.
 - c. Loosen the screw that attaches the A2 Memory Board assembly to the rear chassis of the instrument.
 - d. While holding the spacer that is between the memory board and rear chassis, pull the screw through the hole in the memory board, and remove the spacer.
 - e. Gently disconnect the A2 Memory Board from the A1 Control Board Assembly.
 - f. Gently pull (toward the front of the instrument) on the CRT shield until the shield disengages from the rear panel.
 - g. Remove the shield by sliding it to the side. You might have to lift up slightly on the rear of the shield while sliding it.
 - h. Disconnect W27 at A1J9.

6. Reconnect the A2 Memory Board Assembly.
7. Reconnect the A5 Power Supply outside of the instrument using the cable extender and line module/switch assembly from the service kit.
8. Reconnect the A2 Memory Board.
9. Using a #10 TORX® screwdriver, remove the four screws that attach the keyboard assembly to the instrument front panel. The screws are accessed from the back of the front panel.
10. Remove the keyboard assembly from the instrument by pulling on the knob. The keyboard assembly will pull away from the front of the instrument.
11. Connect the power cord to the line module/switch assembly and set the line switch to ON (|).
12. Set up the keyboard selftest again.

Caution

In the following steps, handle the printed circuit board by the edges. And do not touch the circular black disks on the back side of the elastomeric keypad.

13. Separate the printed circuit keyboard from the elastomeric keypad using the following steps:
 - a. Pull the knob off the front panel.
 - b. Remove the 1/2 inch nut attaching the rotary pulse generator (RPG) to the front panel.
 - c. Lift the printed circuit board away from the elastomeric keypad.
14. Short the traces of any keys that were found to be non-operational during the keyboard selftest. Short the traces with the blade of a screwdriver as shown in figure 2-29.

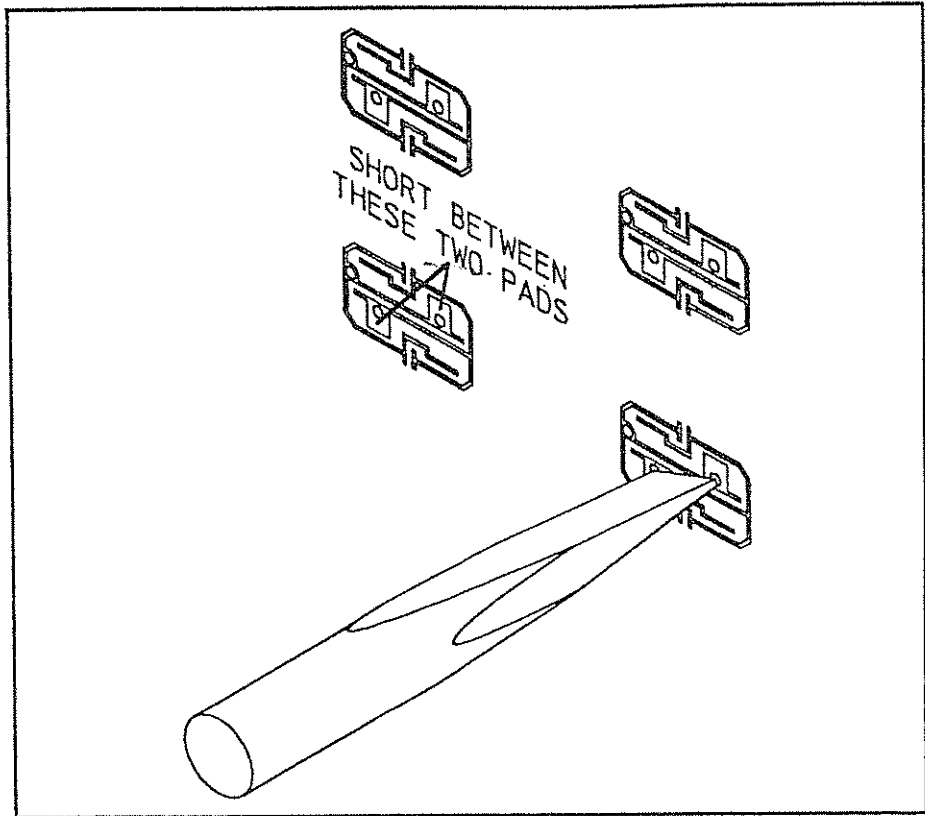

Figure 2-29. Shorting the Keypad Traces

When you short each trace, check for the proper response in the keyboard selftest screen.

15. If the keyboard selftest responds as if a key were pressed, replace the elastomeric keypad. If the display still does not respond, replace the printed circuit keyboard.
16. Reinstall the assemblies that were removed.

To Troubleshoot the Rotary Pulse Generator (RPG)

1. Probe pins 1 and 2 of the keyboard cable connector with an oscilloscope or logic probe. Pin 1 is the square pad and pin 2 is above pin 1. Probe the pins where the cable is soldered to the printed circuit board.
2. Rotate the RPG rapidly while probing pins 1 and 2. You should see a pulse train on these pins when the knob is rotated. If no pulse train appears on either of the pins, replace the RPG assembly. If pulse trains are noted on both pins, the RPG assembly is functioning properly.
3. Reinstall the assemblies that were removed.

Disassembly Procedures

Introduction

This chapter contains the disassembly procedures for the HP 8990A Peak Power Analyzer. Procedures have been included for removal of all major assemblies:

- Power Supply Assembly
- Baseband Board Housing Assembly
- Sensor Check Source Assembly
- Rear Panel Assembly
- Control Board Assembly
- Keyboard Assembly
- Fan
- Feet and Tilt Stand
- CRT Monitor Assembly
- Front Panel Connectors

The procedures do not have to be performed in the order listed. Each procedure can stand by itself.

Throughout the procedures, references are made to the assemblies and cables within the Peak Power Analyzer. Figures 3-1 and 3-2 will be helpful in identifying and locating these assemblies.

Note



When performing the procedures, it is important that you note how the cable assemblies are dressed (routed) within the Peak Power Analyzer. For example, if cable assemblies W21 and W22 (see figure 3-2 for their location within the instrument) are not dressed properly, low level accuracy can be effected.

Tools Required

The following tools are used in the removal procedures:

- 9/32 Socket Wrench
- 17mm Wrench
- 5/16 and 7/16 Wrenches
- Medium Flat Blade Screwdriver
- Medium Pozidriv Screwdriver
- T-10 TORX® Screwdriver
- T-15 TORX® Screwdriver

Warning



The disassembly procedures in this section should only be used after the instrument's power switch has been set to off (\circ) and the instrument has been disconnected from the line (mains) voltage.

The circuitry associated with the Cathode-Ray Tube (CRT) contains very high voltages, even when power is removed. Always follow the procedures when working around the CRT and associated circuits. The procedures will instruct you how to discharge the high voltage.

Service Kit

The procedures "To Remove the Front Panel Connectors" and "To Remove the CRT Monitor Assembly" require the use of special tools. The HP 8990A Service Kit contains the tools required for the procedures. The kit also contains other assemblies used in servicing the Peak Power Analyzer. Order HP part number 08990-60045.

Installing an Assembly

All parts and assemblies in the instrument can be installed by following the pertinent removal procedure in reverse. The removal procedures show the tools needed for removal; these same tools are used to install an assembly or part.

After installing the assembly or part and ensuring that all cables are correctly connected, go to the adjustment section of the HP 8990A Calibration Manual. A table at the beginning of that section will show which adjustments (if any) to perform on the assembly you installed.

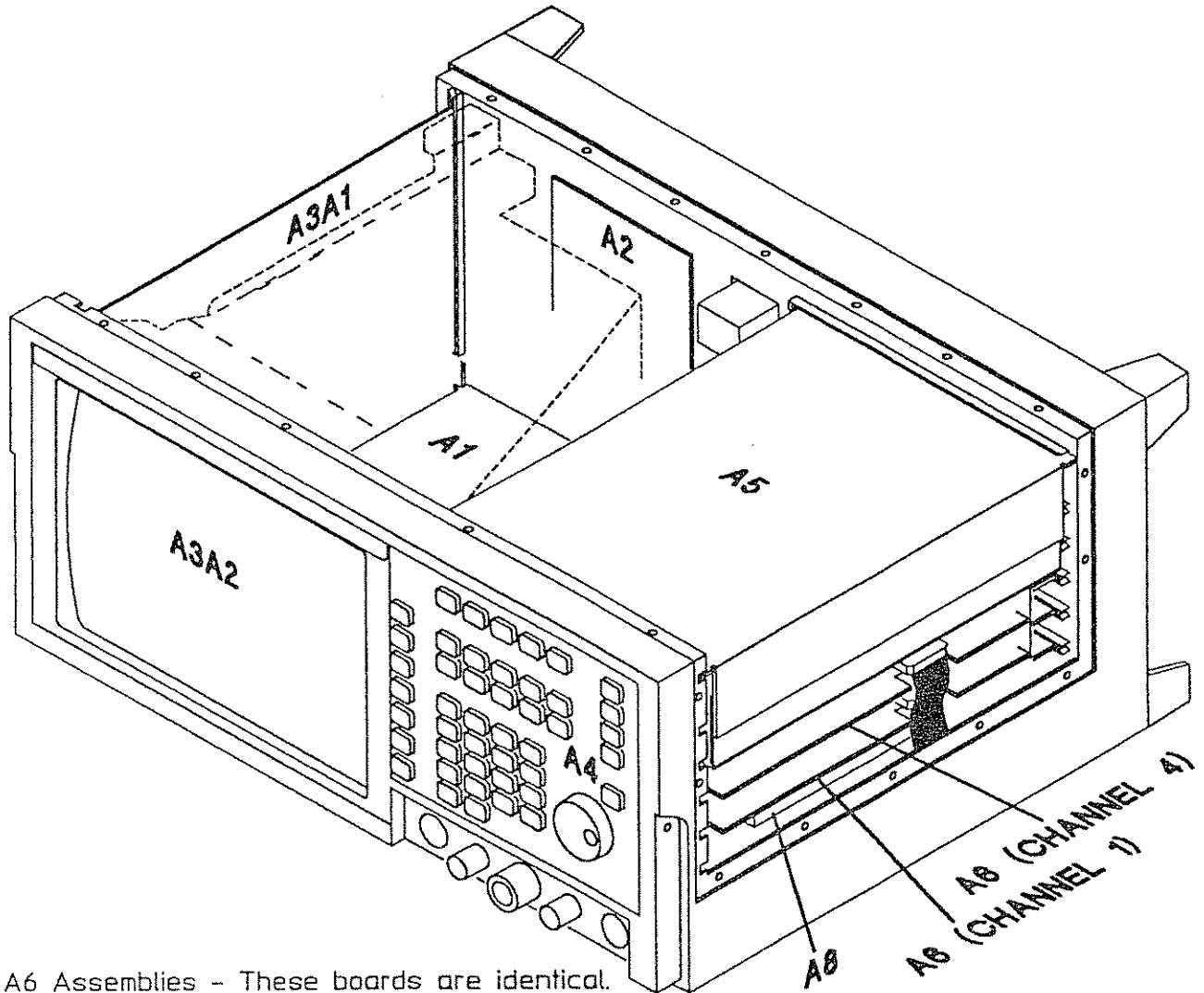

A6 Assemblies - These boards are identical.

A7 designator - not assigned.

Figure 3-1. Major Assemblies

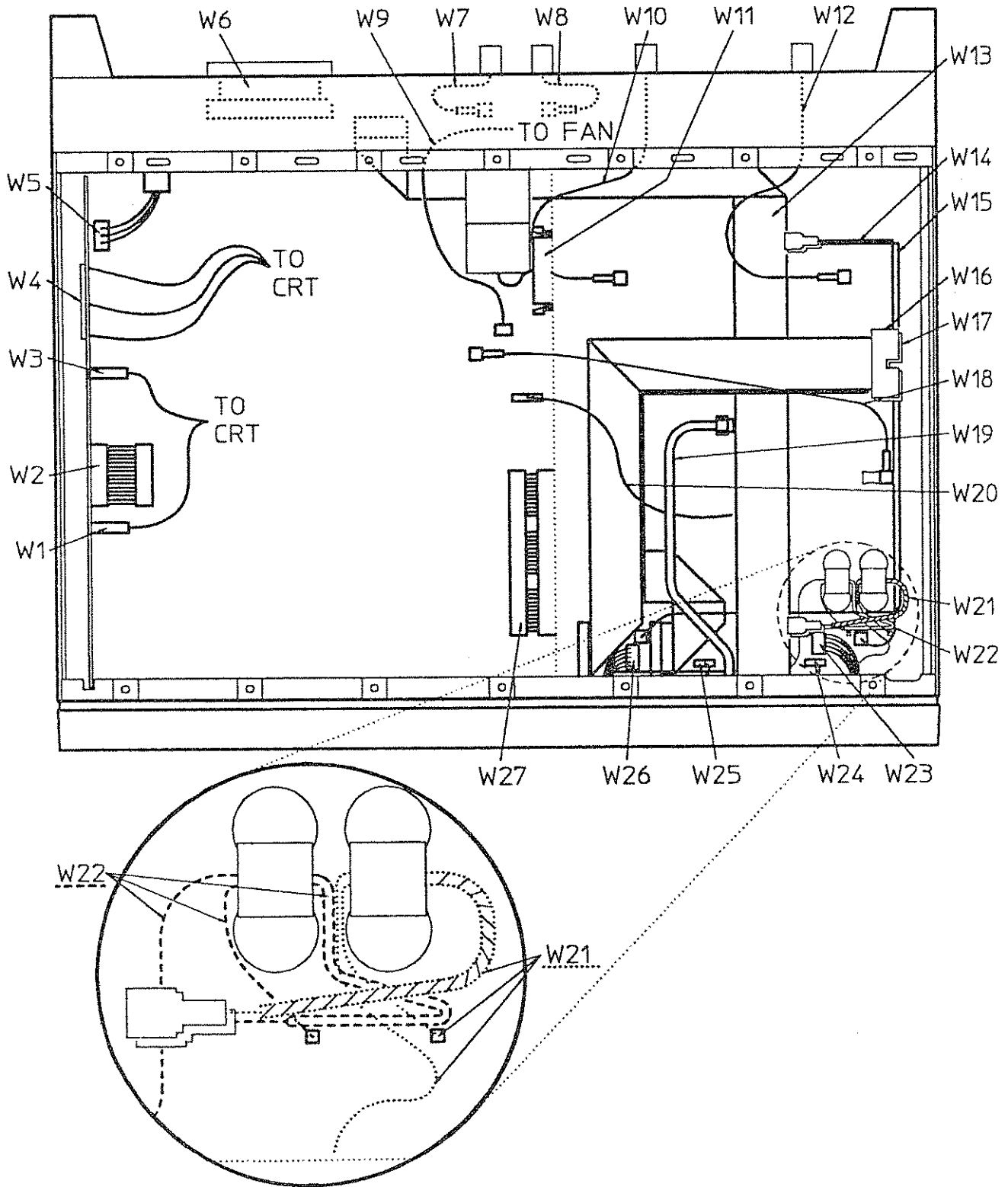

Figure 3-2. Cable Assemblies

To Remove the A5 Power Supply Assembly

1. Set the rear panel line (mains) switch to OFF (○).
2. Disconnect the power cable from the rear of the Peak Power Analyzer.
3. Remove six screws from the top and two screws from each side of the Peak Power Analyzer's cabinet with a #10 TORX® screwdriver.
4. Lift the top cover off.
5. Remove the screw attaching the CRT shield to the A5 Power Supply Assembly.
6. Remove the two PCB (printed circuit board) retainers securing the A5 Power Supply Assembly from the right front and right rear corners of the instrument cabinet. The retainers are removed by pulling up and out.
7. Slide the Power Supply Assembly a little toward the side of the instrument cabinet.
8. Remove the cable (W27) connected from the A5 Power Supply Assembly to the A1 Control Board Assembly.
9. Disconnect the cable from the line module to the A5 Assembly. To remove the cable, squeeze in on the two connector tabs while pulling the connector straight back.
10. Slide the Power Supply Assembly out through the side of the instrument cabinet.

To Remove the A6 Baseband Boards Housing Assembly

1. Set the rear panel line (mains) switch to OFF (○).
2. Disconnect the power cable from the rear of the Peak Power Analyzer.
3. Remove six screws from the top and two screws from each side of the Peak Power Analyzer's cabinet with a #10 TORX® screwdriver.
4. Lift the top cover off.
5. Remove the two screws securing the covers to the A6 Baseband Boards Housing Assembly. Refer to figure 3-3.

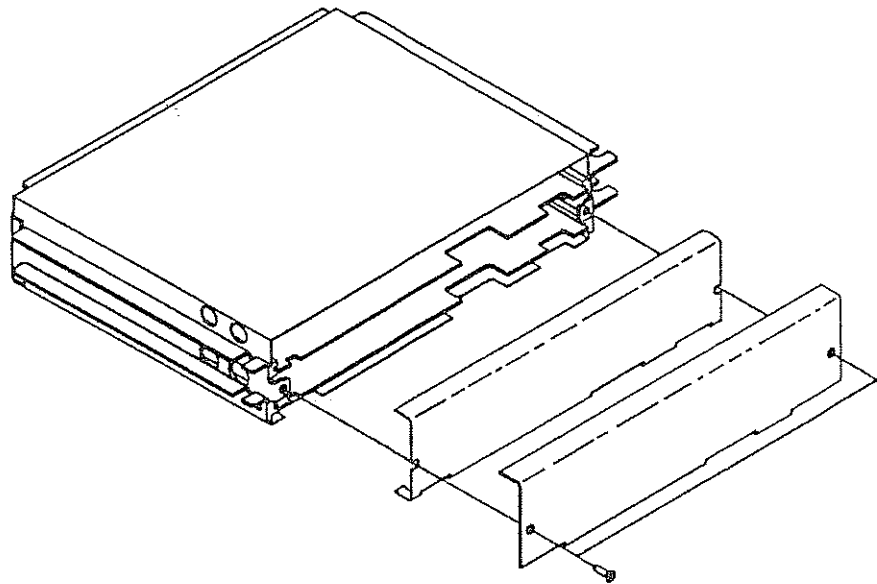

Figure 3-3. A6 Baseband Housing Shield Covers

Note



Before performing the next step, make a note of where the cables are connected. The top board is for RF channel 4 and the bottom board is for RF channel 1.

6. Disconnect the coaxial and ribbon cables connected to the A6 Baseband Board Assemblies.
7. Pull up and out on the two PCB (printed circuit board) retainers securing the A6 Baseband Boards Housing Assembly from the right front and right rear corners of the instrument cabinet.
8. Slide the A6 Baseband Boards Housing Assembly out through the side of the instrument cabinet.

To Remove the A8 Sensor Check Source Assembly

1. Set the rear panel line (mains) switch to OFF (\bigcirc).
2. Disconnect the power cable from the rear of the Peak Power Analyzer.
3. Remove six screws from the top and two screws from each side of the Peak Power Analyzer's cabinet with a #10 TORX® screwdriver.
4. Lift the top cover off.
5. Perform the following procedures in this chapter:
 - “To Remove the A5 Power Supply Assembly”
 - “To Remove the A6 Baseband Boards Housing Assembly”
6. Tuck the coaxial cables under the A8 Sensor Check Source Assembly.
7. Disconnect the simi-rigid cable from the A8 Assembly.

Note



When reconnecting the simi-rigid cable, the torque specification for the connectors is 14 to 16 inch/pounds.

8. Disconnect the coaxial cable (W18; gray and brown) at the A8 Assembly and at the A1 Control Board Assembly.
9. Disconnect the other cable (W20; multiple wires) at the A1 Assembly.
10. Gently pull on the narrower portion of the A8 Assembly. The assembly should come right out.

To Remove the Rear Panel Assembly

1. Set the rear panel line (mains) switch to OFF (\bigcirc).
2. Disconnect the power cable from the rear panel of the Peak Power Analyzer.
3. Detach the line module cable (W11) to the A5 Power Supply.
4. Remove the nine screws from the rear panel with a #10 TORX® screwdriver.
5. Gently pull the rear panel from the cabinet.
6. Disconnect the four coaxial cables and one ribbon cable from the A1 Control Board Assembly.
7. Remove the rear panel from the instrument cabinet.

To Remove the A1 Control Board Assembly

To Gain Access to the Control Board

1. Set the rear panel line (mains) switch to OFF (\bigcirc).
2. Disconnect the power cable from the rear panel of the Peak Power Analyzer.
3. Remove six screws from the top and two screws from each side of the Peak Power Analyzer's cabinet with a #10 TORX® screwdriver.
4. Lift the top cover off.
5. Perform the following procedures in this chapter:
 - “To Remove the A5 Power Supply Assembly”
 - “To Remove the A6 Baseband Boards Housing Assembly”
 - “To Remove the A8 Sensor Check Source Assembly”
 - “To Remove the Rear Panel Assembly”

To Remove the CRT Shield

1. Loosen the screw that attaches the A2 Memory Board assembly to the rear chassis of the instrument.
2. While holding the spacer that is between the memory board and rear chassis, pull the screw through the hole in the memory board, and remove the spacer.
3. Gently disconnect the A2 Memory Board from the A1 Control Board Assembly.
4. Gently pull (toward the front of the instrument) on the CRT shield until the shield disengages from the rear panel.
5. Remove the shield by sliding it to the side. You might have to lift up slightly on the rear of the shield while sliding it.

To Free the Control Board Assembly

1. Disconnect the cable (W2) between the A3A1 Sweep Assembly and the A1 assembly, at the A1 Assembly.
2. Disconnect the fan at the A1 Assembly.
3. Remove the wide cable (W27) connected to the A1 Control Board Assembly.
4. Disconnect the ribbon cable (W13) from the keyboard, at the rear of the A1 Assembly.
5. Disconnect the multi-colored cables (W23 and W26) coming from the channel 1 (CH 1) and channel 4 (CH 4) input connectors.
6. Disconnect the channel 2 (CH 2) and 3 (CH 3) cables (W24 and W25) at the A1 Assembly.

7. Disconnect the cables (W14 and W15) labeled "BB 4" and "BB 1" near the multi-colored cables.

To Disconnect the Toroids

1. Remove the cover holding the two toroids down. They are part of cables W21 and W22.
2. Disconnect the two wires that come from the toroids and are connected to the A1 Assembly.

To Slide the Control Board Assembly Out

1. Remove the three cable clamps on top of the two silver housings. The clamps are removed by prying them off with a flat blade screwdriver. Once the clamps are removed, they can not be reused. The part number for the clamp is 1400-0611.
2. Carefully place the Peak Power Analyzer with it's front panel down or on it's side.
3. Remove the seven (7) TORX® screws on the bottom of the instrument that secure the A1 Control Board Assembly to the cabinet.
4. Slide the A1 Control Board Assembly out of the cabinet through the rear of the instrument.

To Remove the A4 Keyboard Assembly

1. Set the rear panel line (mains) switch to OFF (\bigcirc).
2. Disconnect the power cable from the rear panel of the Peak Power Analyzer.
3. Remove six screws from the top and two screws from each side of the Peak Power Analyzer's cabinet with a #10 TORX® screwdriver.
4. Lift the top cover off.
5. Perform the following procedures in this chapter:
 - "To Remove the A5 Power Supply Assembly"
 - "To Remove the A6 Baseband Boards Housing"
 - "To Remove the A8 Sensor Check Source Assembly"
6. Detach the keyboard cable (W13) from the A1 Control Board Assembly.

Caution



Support the A4 Keyboard Assembly from the front panel while performing the following step. The keyboard may fall from the instrument when the four screws are removed.

7. Remove the four screws securing the A4 Keyboard Assembly with a #10 TORX® screwdriver. The screws are on the backside of the front panel.

8. The A4 Keyboard Assembly (label overlay, housing, keypad, RPG and knob) will come off the front panel as one unit.
9. To disassemble the A4 Keyboard Assembly, use the following steps:

Caution

In the following steps, handle the printed circuit board by the edges. And do not touch the circular black disks on the back side of the elastomeric keypad.

- a. Pull on the knob to remove it from the RPG assembly. The knob press fits over the shaft and will come loose when pulled.
- b. Remove the 7/16 inch nut holding the RPG to the Keyboard Assembly.
- c. Remove the printed circuit board from the front panel.
- d. The elastomeric keypad is not attached to the printed circuit board and may be lifted from the assembly.
- e. Disconnect the RPG cable from the printed circuit board.

Note

If you are replacing the label overlay, you must peel the old label off the keyboard panel and then clean any residual adhesive from the keyboard panel. The best solvent to use for this is an 80:20 solution of isopropyl alcohol and water (IPA/H₂O).

To Remove the Fan

1. Set the rear panel line (mains) switch to OFF ().
2. Disconnect the power cable from the rear panel of the Peak Power Analyzer.
3. Remove six screws from the top and two screws from each side of the Peak Power Analyzer's cabinet with a #10 TORX® screwdriver.
4. Lift the top cover off.
5. Perform the following procedure in this chapter:
 “To Remove the Rear Panel Assembly”
6. Detach the fan cable (W9) from the A1 Control Board Assembly.
7. Remove the four screws securing the fan to the cabinet.

To Remove the Feet and Tilt Stand

1. Set the rear panel line (mains) switch to OFF (\bigcirc).
2. Disconnect the power cable from the rear panel of the Peak Power Analyzer.
3. Remove six screws from the top and two screws from each side of the Peak Power Analyzer's cabinet with a #10 TORX[®] screwdriver.
4. Lift the top cover off.
5. Perform the following procedures in this chapter:
 - “To Remove the A5 Power Supply Assembly”
 - “To Remove the A6 Baseband Boards Housing”
 - “To Remove the A8 Sensor Check Source Assembly”
 - “To Remove the A1 Control Board Assembly”
6. Remove the three #10 TORX[®] screws securing each foot/tilt stand to the bottom of the cabinet.

To Remove the CRT Monitor Assembly

To Access The Control Board Assembly

1. Set the rear panel line (mains) switch to OFF (\bigcirc).
2. Disconnect the power cable from the rear panel of the Peak Power Analyzer.
3. Remove six screws from the top and two screws from each side of the Peak Power Analyzer's cabinet with a #10 TORX[®] screwdriver.
4. Lift the top cover off.
5. Perform the following procedures in this chapter:
 - “To Remove the A5 Power Supply Assembly”
 - “To Remove the A6 Baseband Boards Housing”
 - “To Remove the A8 Sensor Check Source Assembly”
 - “To Remove the Rear Panel Assembly”

To Remove the Control Board Assembly

1. Loosen the screw that attaches the A2 Memory Board assembly to the rear chassis of the instrument.
2. While holding the spacer that is between the memory board and rear chassis, pull the screw through the hole in the memory board, and remove the screw and spacer.
3. Gently pull the A2 Memory Board from the A1 Control Board Assembly.
4. Perform the following procedure in this chapter.

“To Remove the A1 Control Board Assembly”

To Remove the Sweep Board

1. Gently pull (toward the front of the instrument) on the CRT shield until the shield disengages from the rear panel.
2. Lift the tab over the top of the rear chassis and then slide the shield toward the rear as far as it will go.
3. Slide the CRT shield to the right side of the instrument to remove it. You might have to lift up slightly on the rear of the shield while sliding it.

Warning



With the Cathode-Ray Tube (CRT) shield removed, a potential high voltage low current shock hazard exists. Before performing the following procedure, make sure that the screwdriver is connected to the specified grounding lug.

Caution



In the following step, discharge the post accelerator lead to a grounding lug only. Components will be damaged if the post accelerator is discharged to other areas.

4. Connect a jumper lead between the ground lug of the CRT and the shaft of a screwdriver.
5. Discharge the CRT by placing the screwdriver under the protective rubber cap of the post accelerator lead (red cable) and momentarily touching the screwdriver to the metal clip of the post accelerator lead.

Note



The CRT may charge up by itself even while disconnected. Discharge the CRT before handling by shorting the post accelerator terminal of the CRT to the ground lug with a jumper lead.

6. Disconnect the cable (W2) between the A3A1 Sweep Assembly and the A1 assembly, at the A3A1 assembly.
7. Disconnect the post accelerator lead (red cable) from the CRT by firmly squeezing the rubber cap until the metal clip disengages from the CRT.
8. Detach the “MAIN BRIGHT” cable from the A3A1 Sweep Board.

9. Detach the "VER. DY" (green and yellow) and "HOR. DY" (red and blue) cables from the A3A1 Sweep Board.
10. Gently pull the connector off the end of the CRT.
11. Slide the A3A1 Sweep Board up and out of the cabinet slot.

Note

When installing the Sweep Board, it may be necessary to press on the center of the outer shield of the sweep board to allow the board to clear the cabinet support rib.

To Remove the CRT

1. Carefully place the Peak Power Analyzer in the front-panel-down position. Block the front panel closest to the knob so that there is no pressure on the knob.
2. Get the socket, extension, and torque limiting driver from the service kit.
3. Remove the three 9/32 inch nuts securing the CRT to the front panel.
4. Remove the #15 TORX® screw securing the CRT to the front panel.
5. Remove the CRT and ground bracket from the front panel of the Peak Power Analyzer.
6. Finally, remove the CRT screen.

Note

When reinstalling the CRT, make certain the CRT yoke is properly aligned. If you do not have the service kit, the torque specification for the three nuts securing the CRT is 14 inch/pounds.

When the CRT is replaced, it might be necessary to perform the "CRT Monitor Assembly Adjustments" in the adjustment section of the HP 8990A Calibration Manual.

To Remove the Front Panel Connectors
To Access The Connector Block

1. Set the rear panel line (mains) switch to OFF ().
2. Disconnect the power cable from the rear panel of the Peak Power Analyzer.
3. Remove six screws from the top and two screws from each side of the Peak Power Analyzer's cabinet with a #10 TORX® screwdriver.
4. Lift the top cover off.
5. Perform the following procedures in this chapter:

“To Remove the A5 Power Supply Assembly”

“To Remove the A6 Baseband Boards Housing”

“To Remove the A8 Sensor Check Source Assembly”

6. Loosen the screw that attaches the A2 Memory Board assembly to the rear chassis of the instrument.
7. While holding the spacer that is between the memory board and rear chassis, pull the screw through the hole in the memory board, and remove the screw and spacer.
8. Gently pull the A2 Memory Board from the A1 Control Board Assembly.
9. Perform the following procedure in this chapter:
“To Remove the A1 Control Board Assembly”

To Remove the Connectors

1. Remove the knurl-nuts from the channel 2 and channel 3 BNC connectors.
2. Remove the BNC connectors.
3. Remove the knurl-nut from the Type-N Sensor Check Source connector.
4. Remove the Type-N connector and semi-rigid cable.
5. Remove the dress panel from the connector block.
6. Stand the instrument upright.
7. Get the LEMO® punch from the service kit.
8. Remove the center conductors from the channel 1 and 4 connectors using the following steps:
 - a. Position the punch over the center conductor of channel 1.
 - b. Gently push the center conductor from the connector.
 - c. Repeat the procedure for channel 4.
9. Pull the black coaxial cable from the center of the connectors.

Note



When reinstalling the black coaxial cable, push the cable into the center of the connector. The end of the cable will lock in place.

10. Remove the four TORX® screws securing the connector block to the front panel.
11. Remove the channel 1 and channel 4 connectors from the connector block with a 17 mm wrench.

Replaceable Parts

Introduction

This chapter contains information for ordering parts. Tables 4-2 to 4-4 list abbreviations used in the parts list and throughout the manual. Replaceable electrical assemblies are listed in reference designator order in table 4-5. Replaceable cable assemblies are listed in table 4-6. Figures 4-3 through 4-10 identify the replaceable mechanical parts.

Abbreviations

Tables 4-2 to 4-4 list the reference designations, abbreviations, and multipliers used in the parts list, block diagrams, and throughout the manual. Standard abbreviations may be in upper or lower-case letters. However, the replaceable parts lists are computer printouts using only upper-case letters. Thus, abbreviations in the replaceable parts lists are in upper-case letters only.

Replaceable Parts List

Table 4-5 is a list of replaceable electrical assemblies. Table 4-6 is a list of replaceable cable assemblies. They are organized in alphanumeric order by reference designation.

The information given for each part has the following:

- Reference designation
- Hewlett-Packard part number
- Part number check digit (CD)
- Quantity (Qty)
- Part description

Illustrated Replaceable Parts List

Figures 4-3 through 4-10 identify the mechanical replaceable parts. Each figure has a facing table that lists the replaceable parts. The replaceable parts are listed by item-number.

The information given with each item-number has the following:

- Item number
- Hewlett-Packard part number
- Part number check digit (CD)
- Quantity (Qty) represented by the item number in the figure
- Part description

Exchange Assemblies

Table 4-1 lists assemblies within the instrument that may be replaced on an exchange basis. Exchange, factory-repaired and tested assemblies are available only on a trade-in basis. Defective assemblies must be returned for credit. Assemblies required for spare parts stock must be ordered by the new assembly part number.

Table 4-1. Part Numbers for Exchange Assemblies

Reference Designator	Description	Part Number ¹	
		Exchange Assy	New Assy
A1	Control Board	08990-69001	08990-60001
A6	Baseband Board	08990-69041	08990-60041

¹ When ordering extra assemblies for spare parts stock, use new assembly part number only. Exchange orders require return of the defective part.

Parts List Backdating

The replaceable parts lists contain the parts for all instrument configurations. If a part is not used in all instrument configurations, this is indicated with the use of a serial number prefix or range of prefixes.

Parts List Updating

A "Manual Update" package is generated whenever a change is made to the replaceable parts list or the illustrated replaceable parts list. For information on how to order a "Manual Update" package, see "Manual Update Package" in chapter 1.

Ordering Information

When ordering a part listed in the replaceable parts list, include the Hewlett-Packard part number, the check digit, and the quantity required. Address the order to the nearest Hewlett-Packard office. The check digit (CD) will ensure accurate and timely processing of your order.

Note



Within the USA, it is more expedient to order directly from the Hewlett-Packard Parts Center by calling the toll-free number 1-800-227-8164, Monday through Friday, 6AM to 5PM (Pacific Time). Ask your nearest Hewlett-Packard office for information and forms for the "Direct Mail Order System".

Parts Identification

To identify a part not shown or in the "Manual Update" package, contact the parts identification section of your nearest Hewlett-Packard service center. Be prepared to identify the instrument by model and serial number, and to describe the part by type, function, and location within the instrument.

Recommended Spares List

Stocking spare parts for an instrument is often done to ensure quick return to service after a malfunction occurs. Hewlett-Packard prepares a "Recommended Spares" list for this instrument. The contents of the list are based on failure reports and repair data. Quantities given are for one year of parts support. A complimentary copy of the "Recommended Spares" list may be requested from your nearest Hewlett-Packard office.

When stocking parts to support more than one instrument or to support a variety of Hewlett-Packard instruments, it may be more economical to work from one consolidated list than simply adding stocking quantities from the individual instrument lists. Hewlett-Packard will prepare consolidated "Recommended Spares" lists for any number or combination of instruments. Contact your nearest Hewlett-Packard office for details.

Table 4-2. Reference Designations

A assembly	E miscellaneous electrical part	P electrical connector (movable portion); plug	V electron tube
AT attenuator; isolator; termination	F fuse	Q transistor; SCR; triode	VR voltage regulator; breakdown diode
B fan; motor	FL filter	H thyristor	W cable; transmission path; wire
BT battery	H hardware	R resistor	X socket
C capacitor	HY circulator	RT thermistor	Y crystal unit (piezoelectric or quartz)
CP coupler	J electrical connector (stationary portion); jack	S switch	Z tuned cavity; tuned circuit
CR diode; diode thyristor; varactor	K relay	T transformer	
DC directional coupler	L coil; inductor	TB terminal board	
DL delay line	M meter	TC thermocouple	
DS annunciator; signaling device (audible or visual); lamp; LED	MP miscellaneous mechanical part	TP test point	
		U integrated circuit; microcircuit	

Table 4-3. Abbreviations

A ampere	cm centimetre	HET heterodyne	MEG meg (10 ⁶) (used in Parts List)
ac alternating current	D/A digital-to-analog	HEX hexagonal	MET FLM metal film
ACCESS accessory	dB decibel	HD head	MET OX metallic oxide
ADJ adjustment	dBm decibel referred to 1 mW	HDW hardware	MF medium frequency; microfarad (used in Parts List)
A/D analog-to-digital	dc direct current	HF high frequency	MFR manufacturer
AF audio frequency	deg degree (temperature interval or difference)	HG mercury	mg milligram
AFC automatic frequency control	° degree (plane angle)	HI high	MHz megahertz
AGC automatic gain control	°C degree Celsius (centigrade)	HP Hewlett-Packard	mH millihenry
AL aluminum	°F degree Fahrenheit	HPF high-pass filter	mho mho
ALC automatic level control	°K degree Kelvin	HR hour (used in Parts List)	MIN minimum
AM amplitude modulation	DEPC deposited carbon	HV high voltage	min minute (time)
AMPL amplifier	DET detector	Hz Hertz minute (plane angle)
APC automatic phase control	diam diameter	IC integrated circuit	MINAT miniature
ASSY assembly	DIA diameter (used in Parts List)	ID inside diameter	mm millimetre
AUX auxiliary	DIFF AMPL differential amplifier	IF intermediate frequency	MOD modulator
avg average	div division	IMP impregnated	MOM momentary
AWG American wire gauge	DPDT double-pole, double-throw	IN inch	MOS metal-oxide semiconductor
BAL balance	DR drive	INCD incandescent	ms millisecond
BCD binary coded decimal	DSB double sideband	INCL include(s)	MTG mounting
BD board	DTL diode transistor logic	INP input	MTR meter (indicating device)
BE CU beryllium copper	DVM digital voltmeter	INS insulation	mV millivolt
BFO beat frequency oscillator	ECL emitter coupled logic	INT internal	mVac millivolt, ac
BH binder head	EMF electromotive force	kg kilogram	mVdc millivolt, dc
BKDN breakdown	EDP electronic data processing	kHz kilohertz	mVpk millivolt, peak
BP bandpass	ELECT electrolytic	kΩ kilohm	mVp-p millivolt, peak-to-peak
BPF bandpass filter	ENCAP encapsulated	kV kilovolt	mVrms millivolt, rms
BRS brass	EXT external	lb pound	mW milliwatt
BWO backward-wave oscillator	F farad	LC inductance-capacitance	MUX multiplex
CAL calibrate	FET field-effect transistor	LED light-emitting diode	MY mylar
ccw counterclockwise	F/F flip-flop	LF low frequency	μA microampere
CER ceramic	FH flat head	LG long	μF microfarad
CHAN channel	FIL H fillister head	LH left hand	μH microhenry
cm centimeter	FM frequency modulation	LIM limit	μmho micromho
CMO cabinet mount only	FP front panel	LIN linear taper (used in Parts List)	μs microsecond
COAX coaxial	FREQ frequency	lin linear	μV microvolt
COEF coefficient	FXD fixed	LK WASH lock washer	μVac microvolt, ac
COM common	g gram	LO low; local oscillator	μVdc microvolt, dc
COMP composition	GE germanium	LOG logarithmic taper (used in Parts List)	μVpk microvolt, peak
COMPL complete	GHz gigahertz	log logarithm(ic)	μVp-p microvolt, peak-to-peak
CONN connector	GL glass	LPF low pass filter	μVrms microvolt, rms
CP cadmium plate	GRD ground(ed)	LV low voltage	μW microwatt
CRT cathode-ray tube	H henry	m metre (distance)	
CTL complementary transistor logic	h hour	mA millampere	
CW continuous wave		MAX maximum	
cw clockwise		MΩ megohm	

Table 4-3. Abbreviations (continued)

nA nanoampere	PIV peak inverse voltage	R&P rack and panel	TV television
NC no connection	pk peak	RWV reverse working voltage	TVI television interference
N/C normally closed	PL phase lock	S scattering parameter	TWT traveling wave tube
NE neon	PLO phase lock oscillator	s second (time)	U micro (10^{-6})
NEG negative	PM phase modulation	" second (plane angle)	(used in Parts List)
nF nanofarad	PNP positive-negative-positive	S-B slow-blow (fuse)	UF microfarad (used in Parts List)
NI PL nickel plate	P/O part of	(used in Parts List)	
N/O normally open	POLY polystyrene	SCR silicon controlled rectifier;	
NOM nominal	FORC porcelain	screw	UHF ultra-high frequency
NORM normal	POS positive; position(s) (used	SE selenium	UNREG unregulated
NPN negative-positive-negative	in Parts List)	SECT sections	V volt
NPO negative-positive	POSN position	SEMICON semiconductor	VA voltampere
zero (zero temperature	POT potentiometer	SEHF super-high frequency	Vac volts, ac
coefficient)	p-p peak-to-peak	SI silicon	VAR variable
NRFR not recommended for	PP peak-to-peak (used in Parts	SIL silver	VCO voltage-controlled
field replacement	List)	SL slide	oscillator
NSR not separately	PPM pulse-position	SNR signal-to-noise ratio	Vdc volts, dc
replaceable	modulation	SPDT single-pole,	VDCW volts, dc, working
ns nanosecond	PREAMPL preamplifier	double-throw	(used in Parts List)
nW nanowatt	PRF pulse-repetition frequency	SPG spring	V(F) volts, filtered
OBD order by description	PRR pulse repetition rate	SR split ring	VFO variable-frequency
OD outside diameter	ps picosecond	SPST single-pole, single-throw	oscillator
OH oval head	PT point	SSB single sideband	VHF very-high frequency
OP AMPL operational	PTM pulse-time modulation	SST stainless steel	Vpk volts, peak
amplifier	PWM pulse-width modulation	STL steel	Vp-p volts, peak-to-peak
OPT option	PWV peak working voltage	SQ square	Vrms volts, rms
OSC oscillator	RC resistance-capacitance	SWR standing-wave ratio	VSWR voltage standing-wave
OX oxide	RECT rectifier	SYNC synchronize	ratio
oz ounce	REF reference	T timed (slow-blow fuse)	VTO voltage-tuned oscillator
Ω ohm	REG regulated	TA tantalum	VTVM vacuum-tube voltmeter
P peak (used in Parts List)	REPL replaceable	TC temperature compensating	V(X) volts, switched
PAM pulse-amplitude	RF radio frequency	TD time delay	W watt
modulation	RFI radio frequency	TERM terminal	W/ with
PC printed circuit	interference	TFT thin-film transistor	WIV working inverse voltage
PCM pulse-code modulation;	RH round head; right hand	TGL toggle	WW wirewound
pulse-count modulation	RLC resistance-inductance-	THD thread	W/O without
PDM pulse-duration	capacitance	THRU through	YIG yttrium-iron-garnet
modulation	RMO rack mount only	TI titanium	Z ₀ characteristic impedance
pF picofarad	rms root-mean-square	TOL tolerance	
PH BRZ phosphor bronze	RND round	TRIM trimmer	
PHL Phillips	RAM random-access memory	TSTR transistor	
PIN positive-intrinsic-	ROM read-only memory	TTL transistor-transistor logic	
negative			

Table 4-4. Multipliers

Abbreviation	Prefix	Multiple
T	tera	10^{12}
G	giga	10^9
M	mega	10^6
k	kilo	10^3
da	deka	10
d	deci	10^{-1}
c	centi	10^{-2}
m	milli	10^{-3}
μ	micro	10^{-6}
n	nano	10^{-9}
p	pico	10^{-12}
f	femto	10^{-15}
a	atto	10^{-18}

This Page Intentionally Left Blank

Table 4-5. Replaceable Major Assemblies

Reference Designation	HP Part No.	C	Qty	Description	Mfr Code	Manufacturer Part Number
A1	08990-60001	6	1	CONTROL BOARD ASSEMBLY (NEW)	28480	08990-60001
	08990-69001	6	1	CONTROL BOARD ASSEMBLY (RE-STORED)	28480	08990-69001
A2	08990-60002	7	1	MEMORY BOARD ASSEMBLY	28480	08990-60002
A3	2090-0211	8	1	DISPLAY-CRT ASSEMBLY	S4013	
A4	08990-60007	2	1	KEYBOARD ASSEMBLY	28480	08990-60007
A5	08990-60031	2	1	POWER SUPPLY ASSEMBLY	28480	08990-60031
A6	08990-60041	4	1	BASEBAND BOARD ASSEMBLY (NEW)	28480	08990-60041
	08990-69041	4	1	BASEBAND BOARD ASSEMBLY (RE-STORED)	28480	08990-69041
A8	08990-60048	1	1	SENSOR CHECK SOURCE ASSEMBLY	28480	08990-60048
B1	3160-0521	3	1	FAN-TBAX 100-CFM 12VDC		4312-26
U1	9135-0416	8	1	FILTER-LINE IEC 320-TERMS	S4307	FN-1393-2-5-05-12

Table 4-6. Cable Assemblies

Reference Designation	HP Part No.	C D	Qty	Description	Mfr Code	Manufacturer Part Number
W1			1	NOT SEPARATELY REPLACEABLE; PART OF A3 DISPLAY ASSEMBLY	28480	
W2	01650-61601	9	1	CABLE ASSEMBLY-CRT SWEEP BOARD	28480	01650-61601
W3			1	NOT SEPARATELY REPLACEABLE; PART OF A3 DISPLAY ASSEMBLY	28480	
W4			1	NOT SEPARATELY REPLACEABLE; PART OF A3 DISPLAY ASSEMBLY	28480	
W5	01650-61614	4	1	CABLE-INTENSITY ADJUSTMENT; INCLUDES POTENTIOMETER	28480	01650-61614
W6	08990-60006	1	1	CABLE ASSEMBLY-HP-IB	28480	08990-60006
W7	08990-60024	3	1	CABLE ASSEMBLY-AC CAL; INCLUDES J11	28480	08990-60024
W8	08990-60023	2	1	CABLE ASSEMBLY-DC CAL; INCLUDES J10	28480	08990-60023
W9			1	NOT SEPARATELY REPLACEABLE; PART OF THE FAN		
W10	08990-60021	0	1	CABLE ASSEMBLY-CHANNEL 1 TRIG; INCLUDES J9	28480	08990-60021
W11	01650-61602	0	1	CABLE ASSEMBLY-AC POWER SUPPLY	28480	01650-61602
W12	08990-60018	5	1	CABLE ASSEMBLY-CHANNEL 4 TRIG; INCLUDES J8	28480	08990-60018
W13	54503-61610	3	1	CABLE ASSEMBLY-KEYBOARD	28480	54503-61610
W14	08990-60010	7	1	CABLE ASSEMBLY-BASEBAND BOARD; CHANNEL 1	28480	08990-60010
W15	08990-60011	8	1	CABLE ASSEMBLY-BASEBAND BOARD; CHANNEL 4	28480	08990-60011
W16	08990-60016	3	1	RIBBON CABLE-BASEBAND BOARD; CHANNEL 1	28480	08990-60016
W17	08990-60033	4	1	RIBBON CABLE-BASEBAND BOARD; CHANNEL 4	28480	08990-60033
W18	08990-60024	3	1	CABLE ASSEMBLY-COAXIAL	28480	08990-60024
W19	08990-20011	4	1	CABLE ASSEMBLY-SEMI RIGID	28480	08990-20011
W20	08990-60014	1	1	CABLE ASSEMBLY-FOUR WIRES	28480	08990-60014
W21	08990-60032	3	1	CABLE ASSEMBLY; CHANNEL 4	28480	08990-60032
	08990-60036		1	CABLE ASSEMBLY; CHANNEL 4 (OPTION 002)	28480	08990-60036
W22	08990-60009	4	1	CABLE ASSEMBLY; CHANNEL 1	28480	08990-60009
	08990-60035		1	CABLE ASSEMBLY; CHANNEL 1 (OPTION 002)	28480	08990-60035
W23			1	NOT SEPARATELY REPLACEABLE; PART OF W21	28480	
W24	08990-60026	5	1	CABLE ASSEMBLY-CHANNEL 3	28480	08990-60026
W25	08990-60026	5	1	CABLE ASSEMBLY-CHANNEL 2	28480	08990-60026
W26			1	NOT SEPARATELY REPLACEABLE; PART OF W22	28480	
W27	11759-60038	5	1	CABLE ASSEMBLY-POWER SUPPLY	28480	11759-60038
W28	10503A	7	1	BNC/BNC CABLE; USED FOR DELAY CAL	28480	10503A

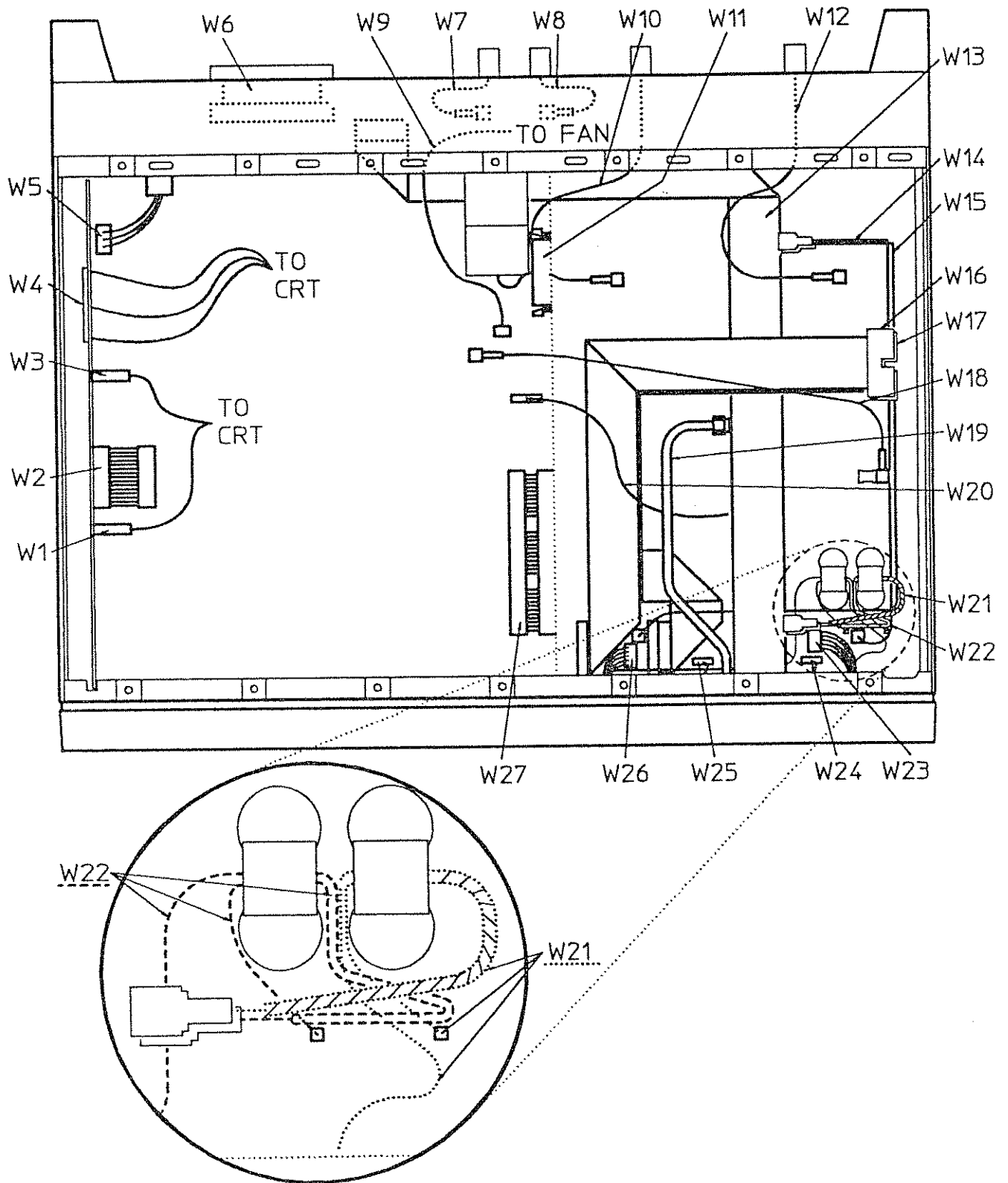

Figure 4-1. HP 8990A Peak Power Analyzer Cable Assemblies

This Page Intentionally Left Blank

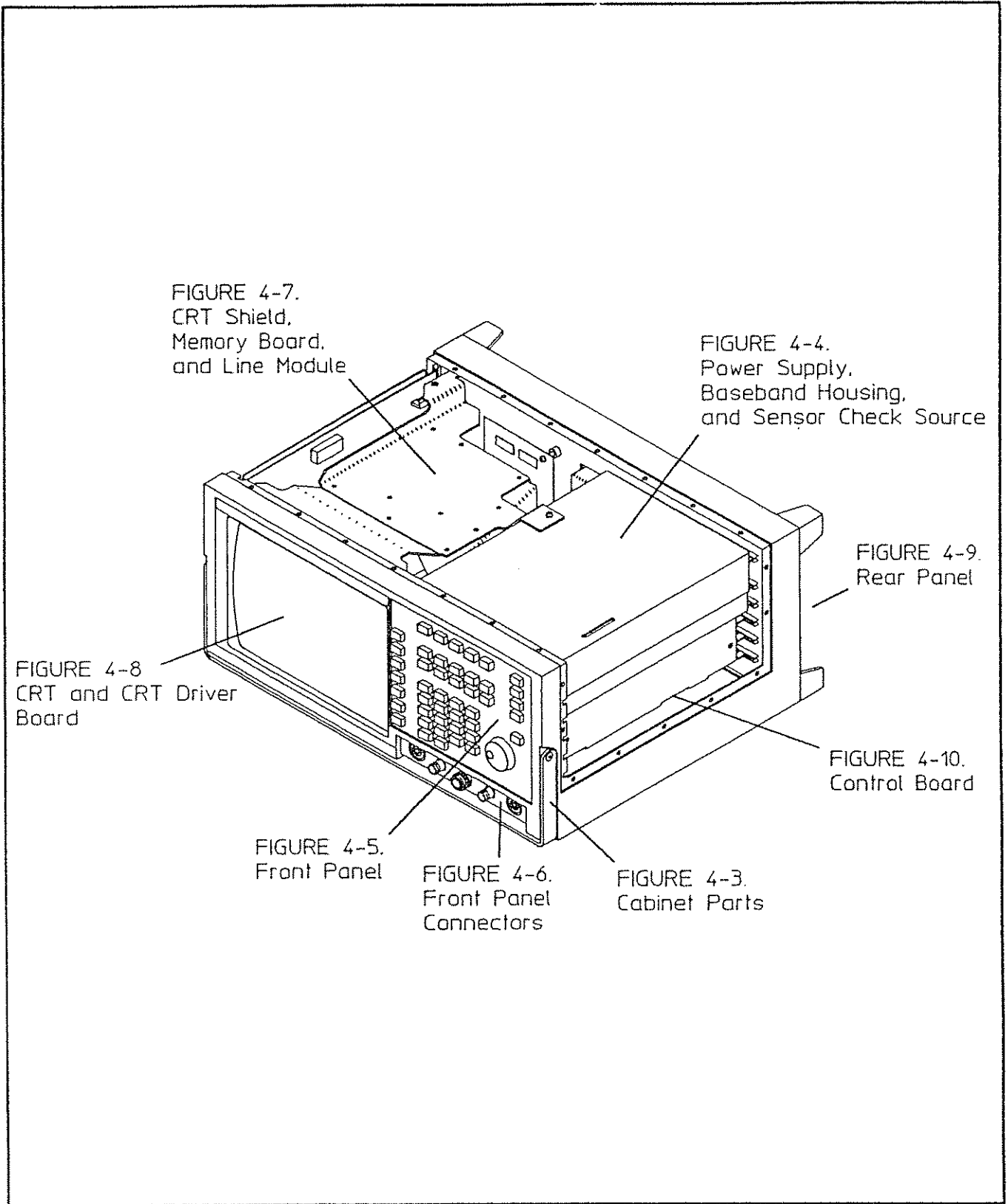

Figure 4-2. Figures Orientation Drawing

Replaceable Parts for Figure 4-3

Reference Designation	HP Part No.	C D	Qty	Description	Mfr Code	Manufacturer Part Number
1	0515-0380	2	1	SCREW-MACHINE ASSEMBLY M4 X 0.7 10MM-LG	93907	
2	01650-04901	2	1	HANDLE-BALE	28480	01650-04901
3	0515-1035	6	2	SCREW-MACH M3 X 0.5 8MM-LG 90-DEG-FLH-HD	93907	
4	01650-84802	0	1	POUCH ACCESSORY	28480	01650-84802
5	08990-00013	4	1	COVER	28480	08990-00013
6	0515-1035	6	6	SCREW-MACH M3 X 0.5 8MM-LG 90-DEG-FLH-HD	93907	
7	0515-1035	6	4	SCREW-MACH M3 X 0.5 8MM-LG 90-DEG-FLH-HD	93907	
8	0515-0380	2	1	SCREW-MACHINE ASSEMBLY M4 X 0.7 10MM-LG	93907	
9	08990-40002	5	1	MOLDED HOUSING	28480	08990-40002
10	0515-1035	6	2	SCREW-MACH M3 X 0.5 8MM-LG 90-DEG-FLH-HD	93907	

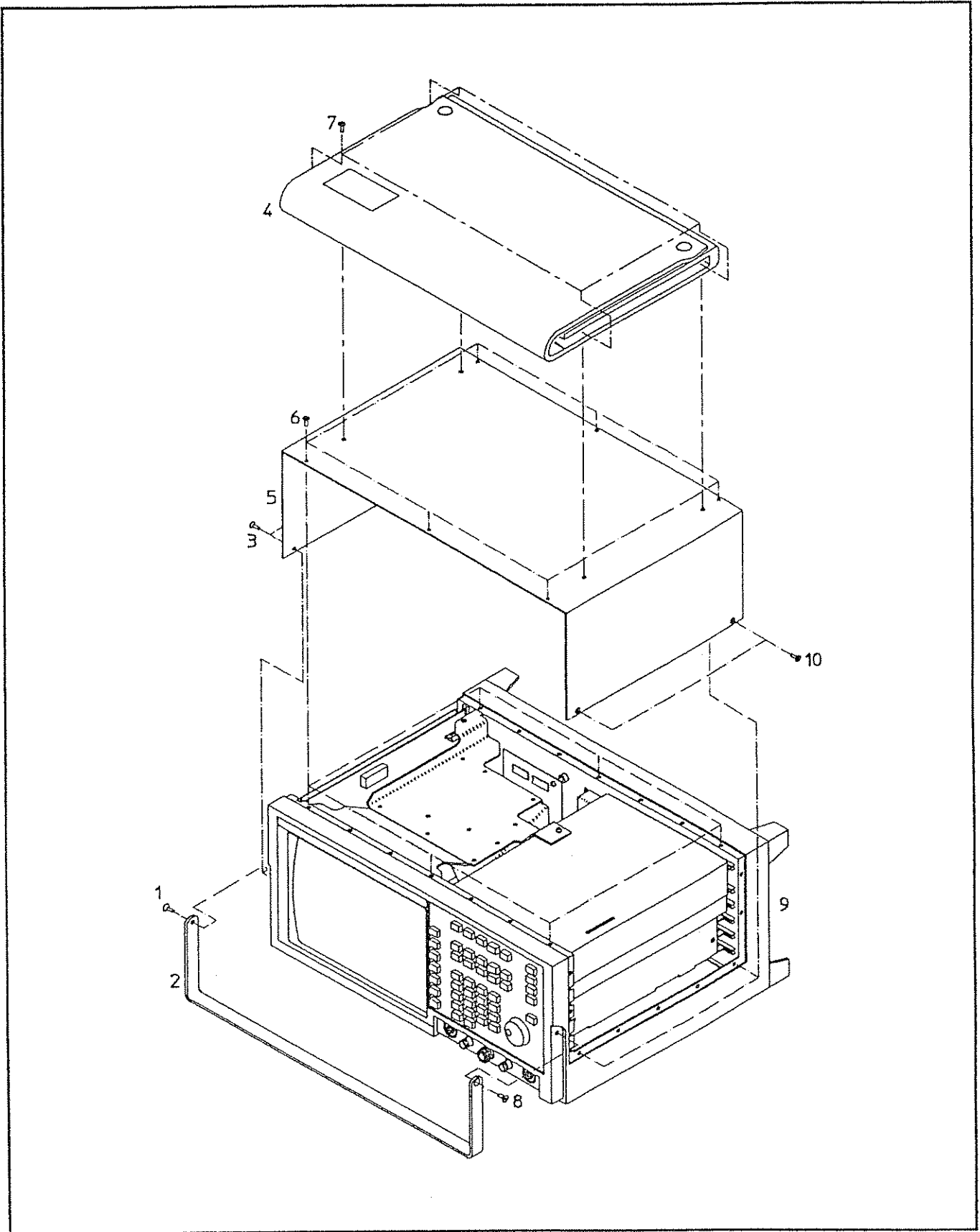

Figure 4-3. Cabinet Parts

Replaceable Parts for Figure 4-4

Reference Designation	HP Part No.	C D	Qty	Description	Mfr Code	Manufacturer Part Number
1	2360-0401	1	1	SCREW-MACH 6-32 .25-IN-LG UNCT 82 DEG	73734	
2			1	A5 POWER SUPPLY ASSEMBLY (REFER TO TABLE 4-3)	28480	
3	08990-00053	2	1	BASEBAND SHIELD (REPLACEMENT FOR ALL INSTRUMENT CONFIGURATIONS.)	28480	08990-00053
4	08990-00010	1	1	PLATE SENSOR CHECK	28480	08990-00010
5	08990-20017	0	1	SENSOR CHECK HSG	28480	08990-20017
6	01650-46101	2	2	LOCKING PIN PCB	28480	01650-46101
7			1	NOT SEPARATELY REPLACEABLE, PART OF ITEM 3	28480	
8	0515-1946	8	8	SCREW-MACH M3 X 0.5 6MM-LG 90-DEG-FLH-HD		
9			1	NOT SEPARATELY REPLACEABLE, PART OF ITEM 3	28480	
10	0515-0372	2	2	SCREW-MACHINE ASSEMBLY M3 X 0.5 8MM-LG	93907	

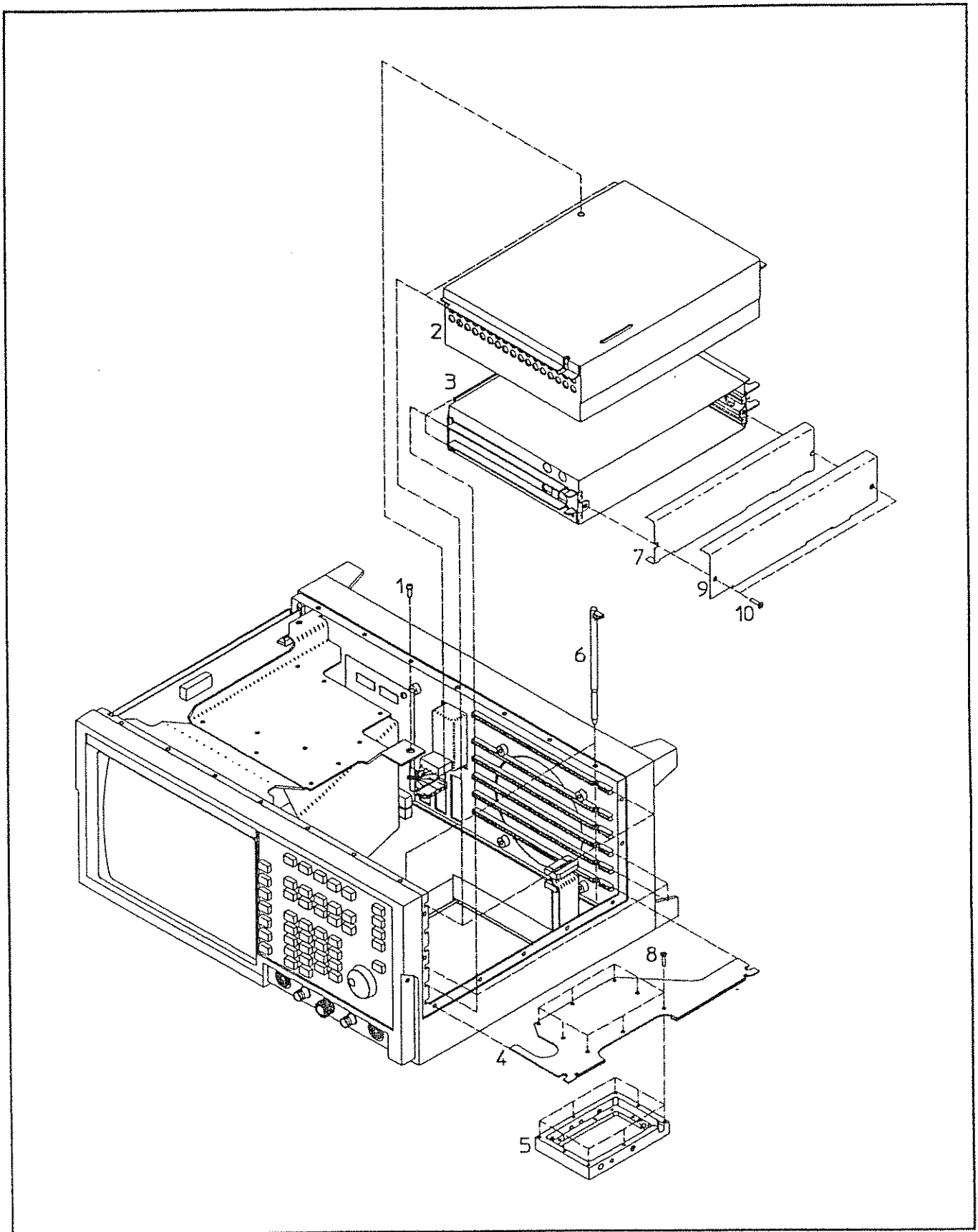

Figure 4-4. Power Supply, Baseband Housing, and Sensor Check Source Illustrated Parts Breakdown

Replaceable Parts for Figure 4-5

Reference Designation	HP Part No.	C D	Qty	Description	Mfr Code	Manufacturer Part Number
1	08990-80003	0	1	KEYBOARD LABEL	28480	08990-80003
2	01650-47401	7	1	KNOB-RPG	28480	01650-47401
3	54503-45207	0	1	PANEL-KEYBOARD	28480	54503-45207
4	2950-0001	8	1	NUT-HEX-DBL-CHAM 3/8-32-THD .094-IN-THK	73734	9002-NP
5	08990-40001	4	1	ELASTOMERIC KEYPAD	28480	08990-40001
6	54503-26502	8	1	KEYBOARD BOARD	28480	54503-26502
7	0960-0753	6	1	ROTARY PULSE GENERATOR SHAFT LENGTH	28480	QEDS-7090
8	0515-1134	6	4	SCREW-MACHINE M3 X 0.5 18MM-LG	28480	0515-1134

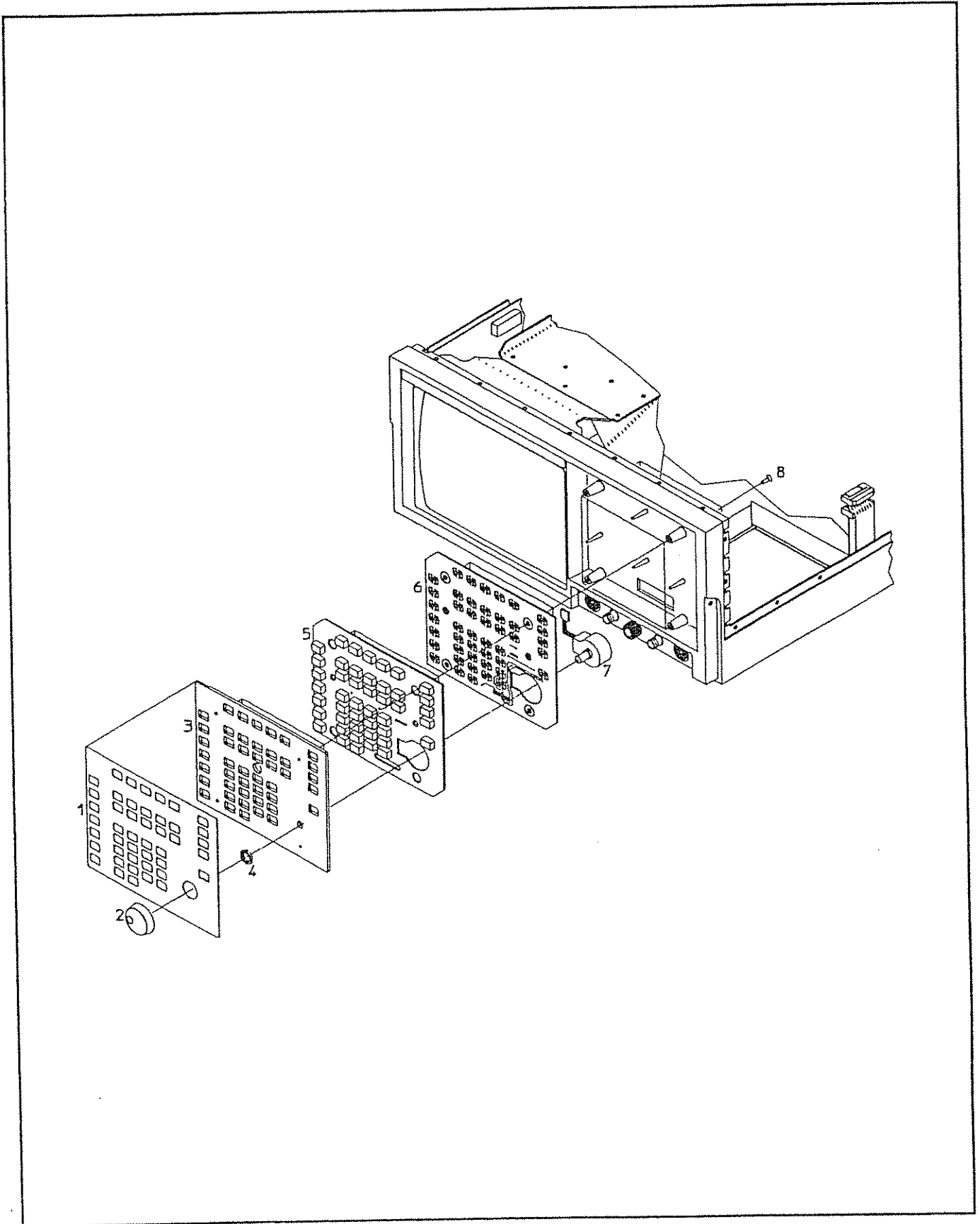

Figure 4-5. Front Panel Illustrated Parts Breakdown

Replaceable Parts for Figure 4-6

Reference Designation	HP Part No.	C D	Qty	Description	Mfr Code	Manufacturer Part Number
1			1	J1; PART OF W22 (REFER TO TABLE 4-4)	28480	
2	0590-1649	6	1	NUT-KNRLD-R 15/32-32-THD .08-IN-THK		
3	08990-00012	3	1	DRESS PANEL	28480	08990-00012
	08990-00030	5	1	DRESS PANEL (OPTION 002)	28480	08990-00030
4	0590-0505	1	1	NUT-KNRLD-R 5/8-24-THD .125-IN-THK	3D855	TD-801
5	0590-1649	6	1	NUT-KNRLD-R 15/32-32-THD .08-IN-THK		
6	0515-0379	9	1	SCREW-MACHINE ASSEMBLY M3.5 X 0.6	93907	
7			1	J5; PART OF W21 (REFER TO TABLE 4-4)	28480	
8	1250-1772	7	1	J3	98291	
9	08990-20006	7	1	CONNECTOR BLOCK	28480	08990-20006
10	0515-0379	9	1	SCREW-MACHINE ASSEMBLY M3.5 X 0.6	93907	
11	0515-0379	9	1	SCREW-MACHINE ASSEMBLY M3.5 X 0.6	93907	
12				PART OF W22; NOT SEPARATELY REPLACEABLE (REFER TO TABLE 4-4)		
13			1	J2; PART OF W25 (REFER TO TABLE 4-4)	28480	
14				PART OF W22; NOT SEPARATELY REPLACEABLE (REFER TO TABLE 4-4)		
15			1	J4; PART OF W24 (REFER TO TABLE 4-4)	28480	
16				PART OF W21; NOT SEPARATELY REPLACEABLE (REFER TO TABLE 4-4)		
17				PART OF W21; NOT SEPARATELY REPLACEABLE (REFER TO TABLE 4-4)		
18	08990-00011	2	1	PC BRACKET	28480	08990-00011

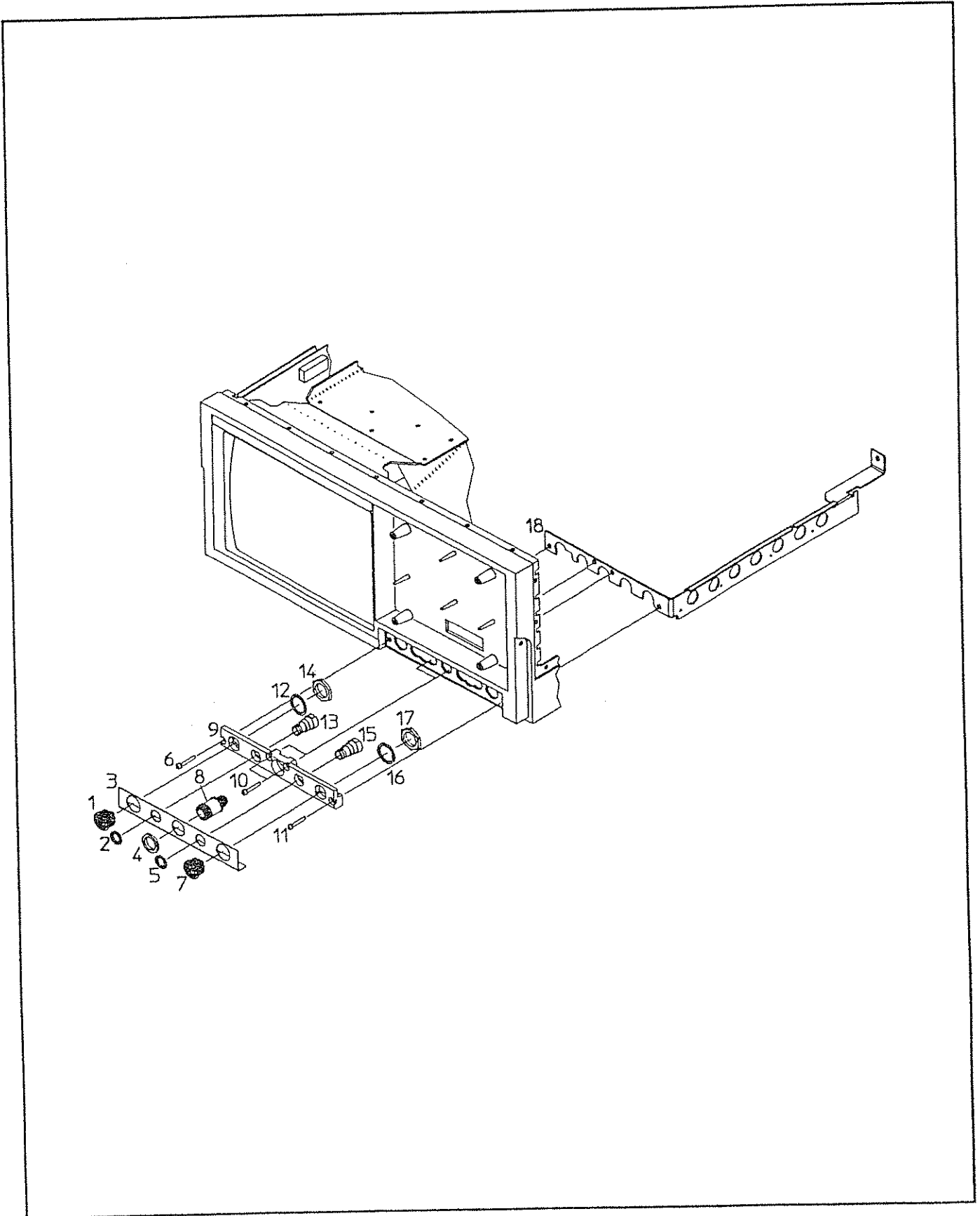

Figure 4-6. Front Panel Connectors Illustrated Parts Breakdown

Replaceable Parts for Figure 4-7

Reference Designation	HP Part No.	C D	Qty	Description	Mfr Code	Manufacturer Part Number
1	08990-00027	0	1	CRT SHIELD BRKT	28480	08990-00027
2	0515-0830	7	1	SCREW-MACHINE ASSEMBLY M3 X 0.5 28MM-LG	93907	
3			1	A2 MEMORY BOARD AY (REFER TO TABLE 4-3)	28480	
4	0380-0010	8	1	SPACER-RND .625-IN-LG .18-IN-ID	74323	
5			1	U1-LINE FILTER (REFER TO TABLE 4-3)		
6	0515-1035	6	2	SCREW-MACH M3 X 0.5 8MM-LG 90-DEG-FLH-HD	93907	

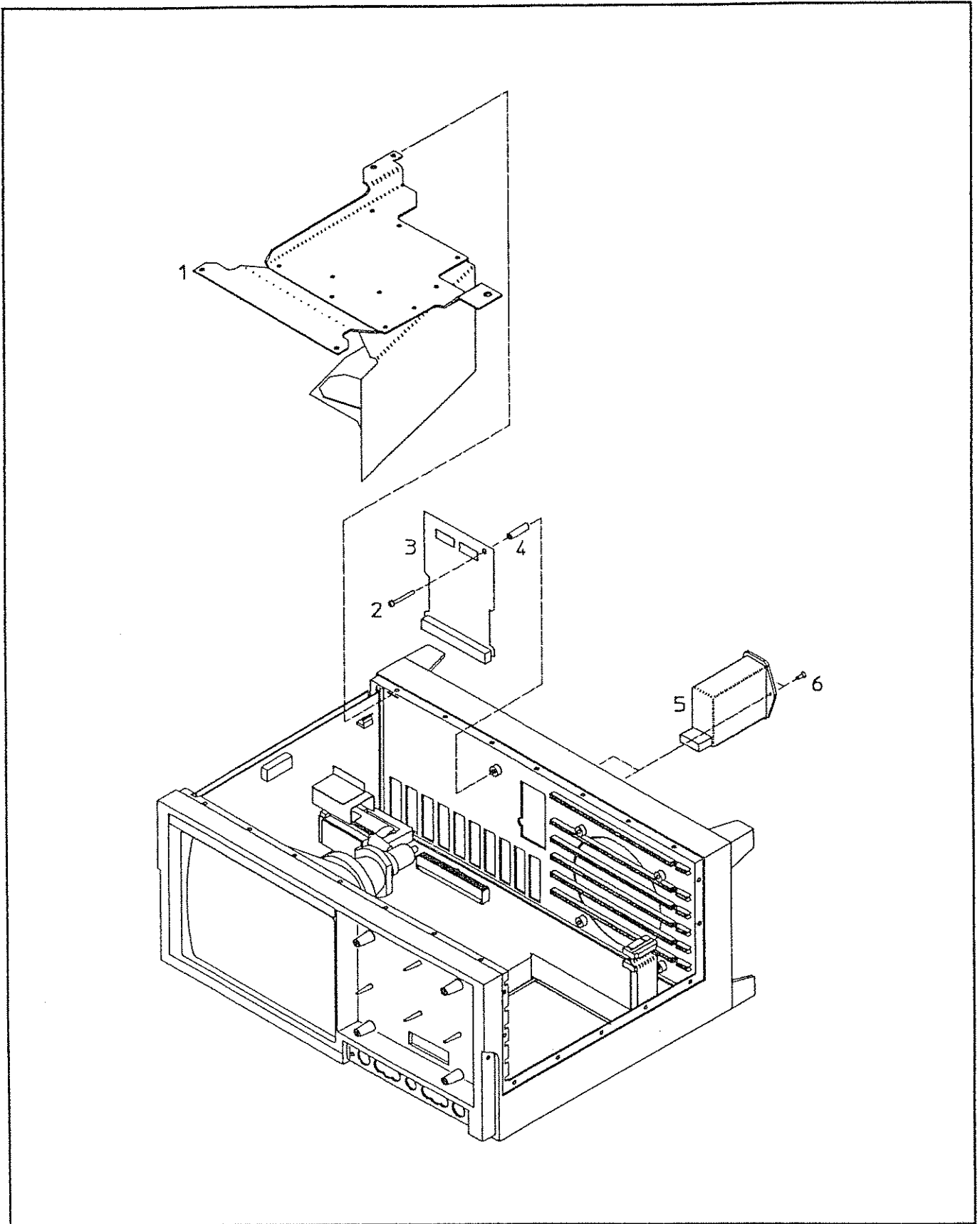

Figure 4-7. CRT Shield, Memory Board, and Line Module Illustrated Parts Breakdown

Replaceable Parts for Figure 4-8

Reference Designation	HP Part No.	C D	Qty	Description	Mfr Code	Manufacturer Part Number
1			1	PART OF A3 DISPLAY ASSEMBLY	S4013	
2 ¹	54503-02701	9	1	FILTER SCREEN		
3			1	A3 DISPLAY ASSEMBLY (REFER TO TABLE 4-3)		
4	01650-01202	0	1	BRACKET-GROUND	28480	01650-01202
5	0535-0056	1	2	NUT-HEX PRVLG-TRQ M4 X 0.7 5MM-THK	39428	
6	0515-0380	2	1	SCREW-MACHINE ASSEMBLY M4 X 0.7 10MM-LG	93907	
7	0535-0056	1	1	NUT-HEX PRVLG-TRQ M4 X 0.7 5MM-THK	39428	

1 For instruments prefixed below 3217A, order front panel window retrofit kit 08990-~~60041~~ ⁶⁰⁰⁴⁷ when ordering this part. The kit is needed to install the filter screen.

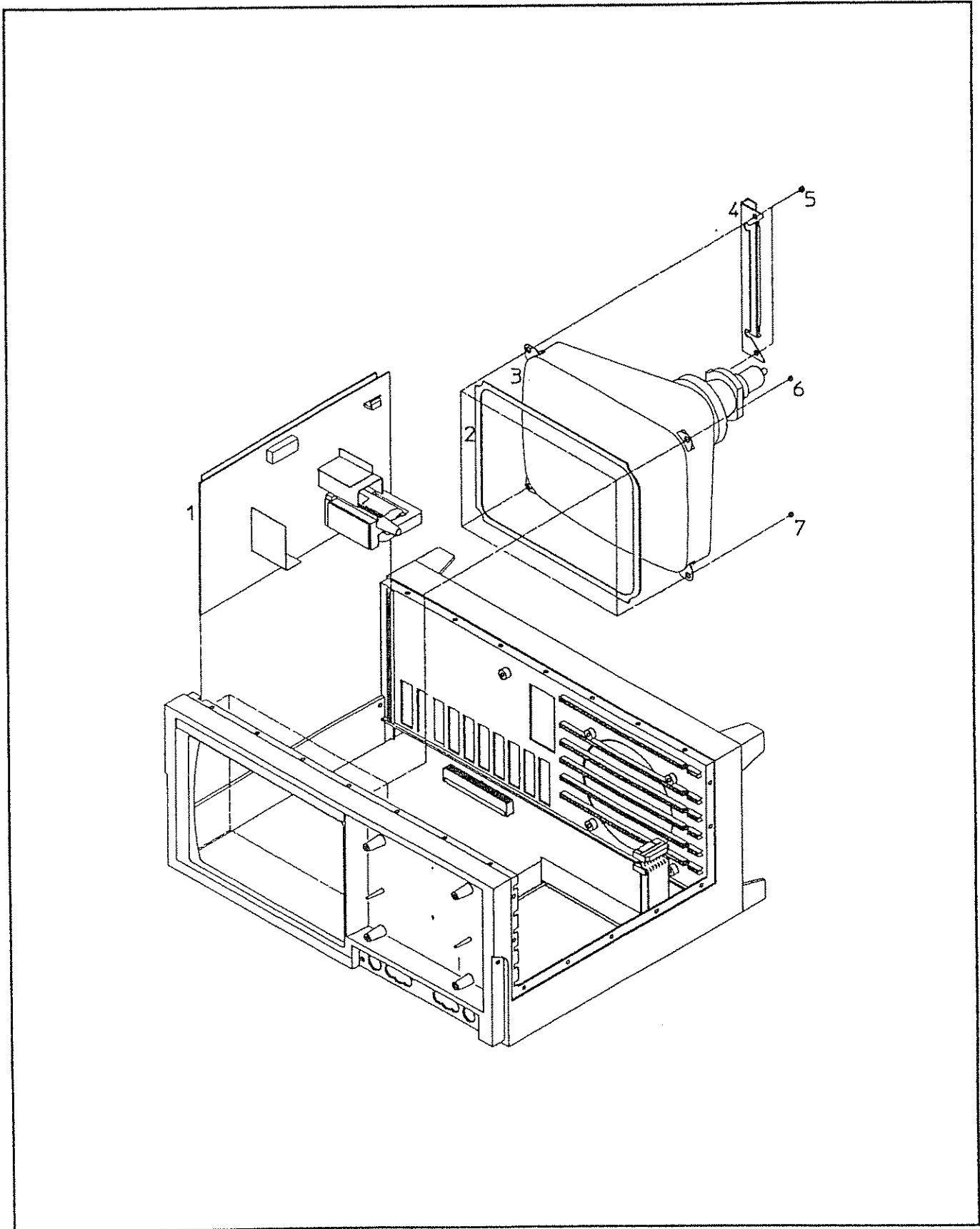

Figure 4-8. CRT and CRT Driver Board Illustrated Parts Breakdown

Replaceable Parts for Figure 4-9

Reference Designation	HP Part No.	C D	Qty	Description	Mfr Code	Manufacturer Part Number
1			1	PART OF W5 (REFER TO TABLE 4-4)	28480	
2			1	B1-FAN (REFER TO TABLE 4-3)		
3	0515-0374	4	4	SCREW-MACHINE ASSEMBLY M3 X 0.5 10MM-LG	93907	
4			1	J8; PART OF W12 (REFER TO TABLE 4-4)	28480	
5	54503-87601	6	1	BANANA PLUG		
6		4	1			
7			1	J9; PART OF W10 (REFER TO TABLE 4-4)	28480	
8	2950-0202	1	1	NUT-HEX-DBL-CHAM 1/4-32-THD		
9	2190-0027	6	1	WASHER-LK INTL T 1/4 IN .256-IN-ID		
10	6960-0121	8	2	PLUG-HOLE DOME-HD FOR .625-D-HOLE BRS	57771	
11			1	J10; PART OF W8 (REFER TO TABLE 4-4)	28480	
12	1510-0038	8	1	BINDING POST ASSY SGL THD-STUD		
13	2190-0027	6	1	WASHER-LK INTL T 1/4 IN .256-IN-ID	78189	1914-00
14			1	J11; PART OF W7 (REFER TO TABLE 4-4)	28480	
15	08990-00001	0	1	REAR PANEL	28480	08990-00001
16	2950-0006	3	1	NUT-HEX-DBL-CHAM 1/4-32-THD .094-IN-THK	73734	9000
17	0515-0374	4	4	SCREW-MACHINE ASSEMBLY M3 X 0.5 10MM-LG	93907	
18	0515-0380	2	1	SCREW-MACHINE ASSEMBLY M4 X 0.7 10MM-LG	28480	0515-0380
19	2190-0102	8	4	WASHER-LK INTL T 15/32 IN .472-IN-ID	78189	1922-01
20	2950-0035	8	4	NUT-HEX-DBL-CHAM 15/32-32-THD	73076	
21	6960-0041	1	3	PLUG-HOLE TR-HD FOR .5-D-HOLE NYL	28520	2643 (BLACK)
22			1	J12; PART OF W6 (REFER TO TABLE 4-4)	28480	
23	0590-0076	1	1	NUT-HEX-PLSTC LKG 4-40-THD .143-IN-THK	72962	21NM-40
24	0515-0374	4	4	SCREW-MACHINE ASSEMBLY M3 X 0.5 10MM-LG	93907	
25	0590-0076	1	1	NUT-HEX-PLSTC LKG 4-40-THD .143-IN-THK	72962	21NM-40

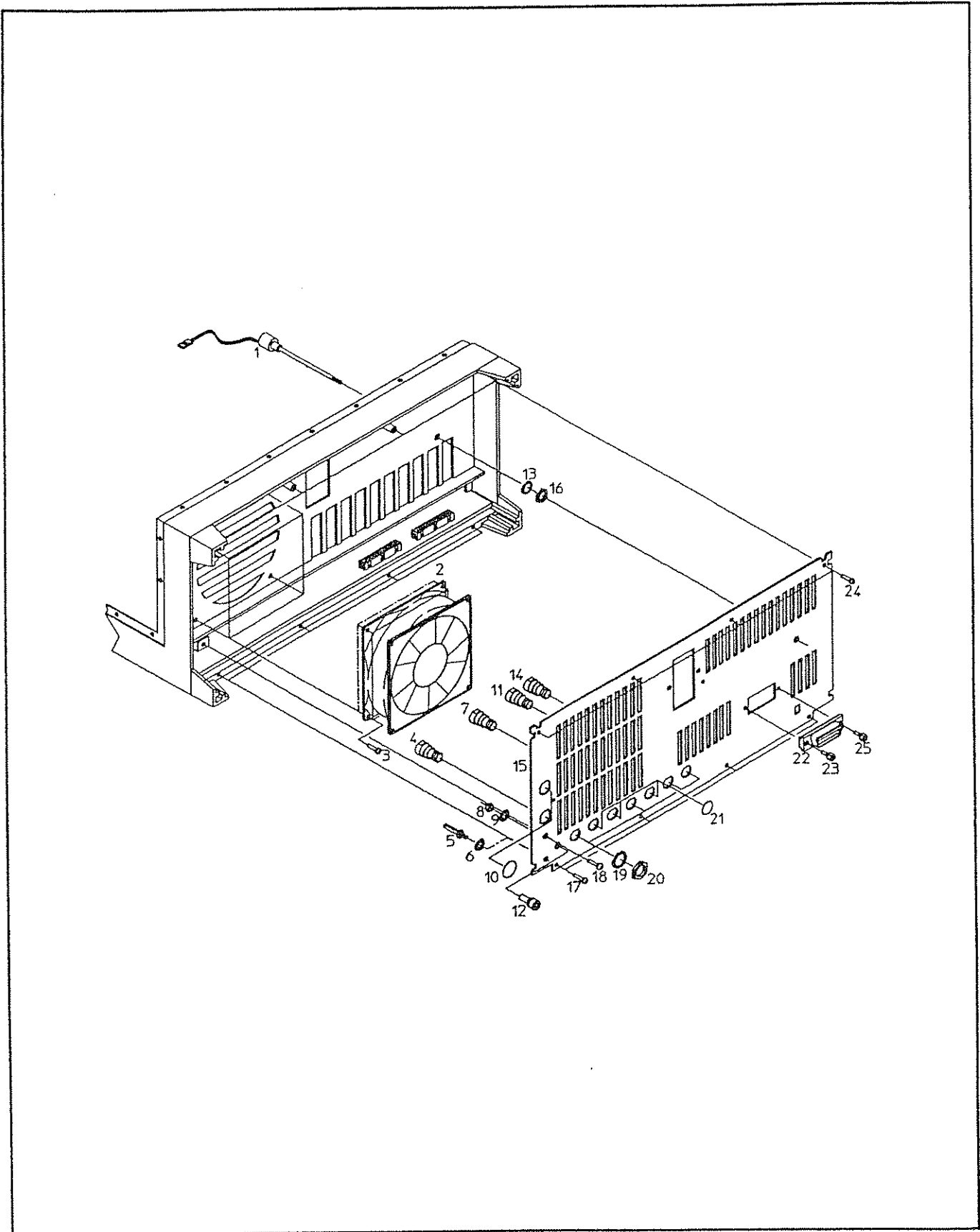

Figure 4-9. Rear Panel Illustrated Parts Breakdown

Replaceable Parts for Figure 4-10

Reference Designation	HP Part No.	C	Qty	Description	Mfr Code	Manufacturer Part Number
1	01650-47701	0	2	FOOT-MOLDED	28480	01650-47701
2	1460-1345	5	2	TILT STAND SST		
3			1	A1 CONTROL BD ASSEMBLY (REFER TO TABLE 4-3)	28480	
4	08990-00029	2	1	TORROID CLAMP	28480	08990-00029
5	0515-0430	3	2	SCREW-MACHINE ASSEMBLY M3 X 0.5 6MM- LG		
6	0515-0374	4	7	SCREW-MACHINE ASSEMBLY M3 X 0.5 10MM-LG	93907	

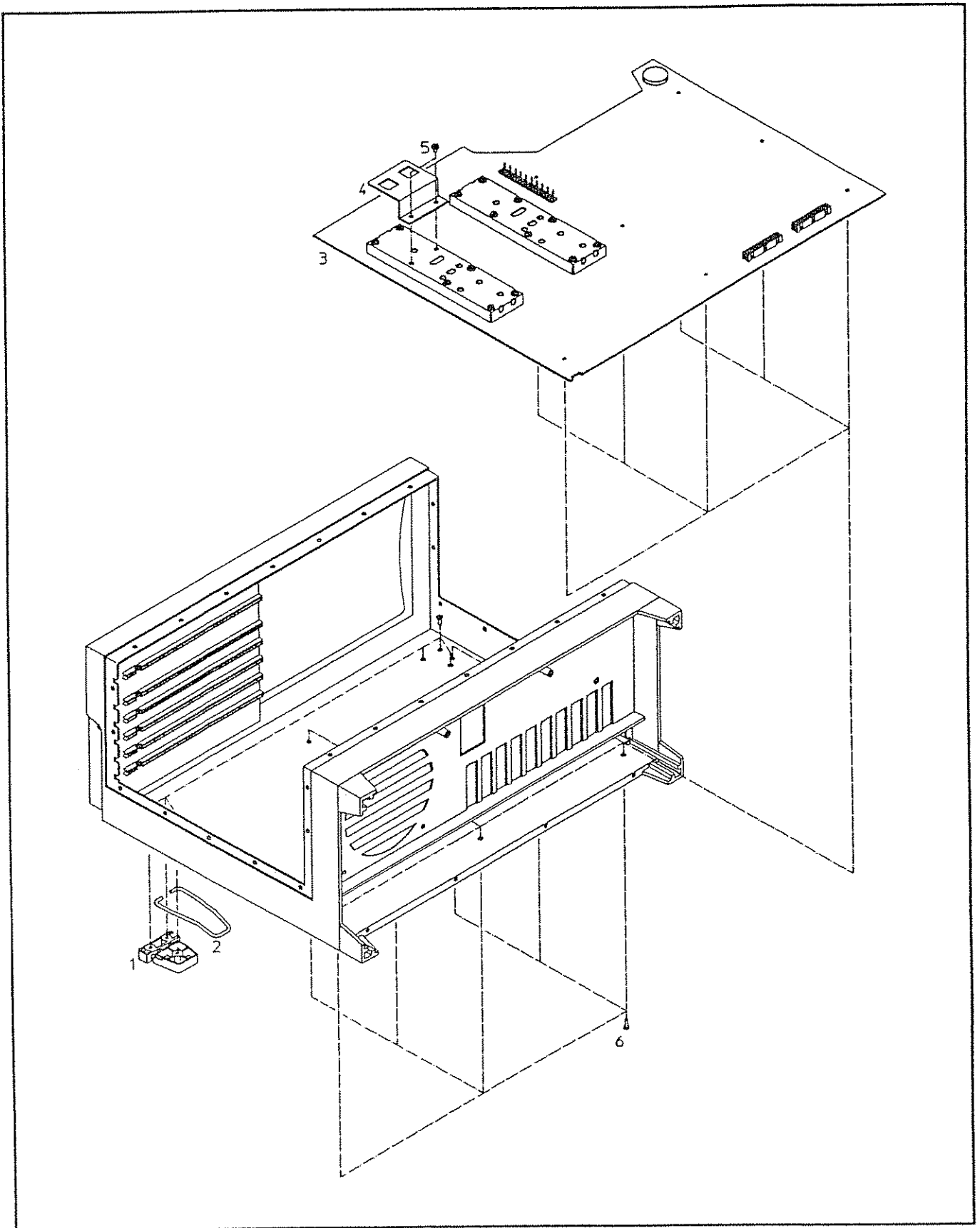

Figure 4-10. Control Board Illustrated Parts Breakdown

Reference

Introduction

This is the reference chapter of the HP 8990A Peak Power Analyzer Service Guide. The purpose of the chapter is to document the service features that exist for the Peak Power Analyzer. Some of these features are used in the troubleshooting. The other features are better suited to component level troubleshooting, they have been placed here as information the technician may be interested in reading about. You will find the following topics described in this chapter:

- Service Menu
- Service Remote Commands
- Self-tests
- Vertical Calibration Failure Codes

Service Menu

The service menu contains functions that are for factory use and used during service procedures. The service menu is diagramed in figure 5-1. Since the service menu should be used only by trained service personnel, the following descriptions broadly describe the different areas of the menu. If an area of the service menu is used in the troubleshooting procedure, use of the menu will be described in that procedure.

Note



The service menu should only be used by trained service personnel.

The PROTECTED SYSTEM CAL section (cal select 0) includes firmware calibrations that need to be done only after repair or during routine service.

SETUPS FOR INTERNAL ADJUSTMENT AND FREQUENCY VERIFY (cal selects 1,2) provide certain signals at the rear panel BNC outputs, for making checks or adjustments.

PROTECTED SYSTEM CAL DEFAULTS (cal select 3) loads baseline firmware calibration factors that are necessary for some adjustment procedures.

DIRECT HARDWARE CONTROL (cal select 4,5) is for factory use and field calibration of the peak power sensor.

MASK

The command :CALIBRATE:MASK is used to mask selected vertical calibrations. During servicing of the Peak Power Analyzer, it may be desired to run one or more calibrations over and over again. The command allows the user to run the desired calibration(s) and suppress the others. This command could be used to repeatedly run selected calcs while checking for loose cables, etc. When the non-masked calibrations are run, the results are saved over the previous results of those calibrations. The mask bits are described in the table below.

The :CALIBRATE:MASK query returns the current mask setting.

Vertical Calibration Mask Byte

Bit	Weight	Calibration
7	128	Unused bit
6	64	Power Trig Cal
5	32	Power Gain Cal
4	16	Unused bit
3	8	Voltage Trig Cal
2	4	Voltage Offset Cal
1	2	Voltage Gain Cal
0	1	Unused bit

Command Syntax: :CALIBRATE:MASK <value>

Where:

<value> ::= 0 to 255 (integer—NR1 format)

Example:

OUTPUT 707;":CALIBRATE:MASK 223"

To enable a calibration, set the bit false. In the example, the power gain cal (bit 5) would be executed.

Query Syntax: :CALibrate:MASK?

Returned Format:

[;CALibrate:MASK] <value><NL>

Where:

<value> ::= 0 to 255 (integer—NR1 format)

Example:

```
DIM Mask$[100]
OUTPUT 707;" :CAL:MASK?"
ENTER 707;Mask$
PRINT Mask$
END
```

PAGAIN

The command :CALIBRATE:PAGAIN is used to attenuate the post-amplifier gain on any channel. This command is useful for isolating gain problems to the A1 Control Board. After using this command the instrument measured power level probably will be inaccurate, and it may be off the screen. The post amplifier gain may be reset by a chopping cycle, which may be caused by a change in temperature at the peak power sensor, a range change, etc. To avoid the reset, under the service menu of the Utility Menu, set "Chopping" to OFF. Do not make a range change once the command has been used. When finished using the command, remember to set "Chopping" to ON. The available attenuation is listed in the following table.

The :CALIBRATE:PAGAIN query returns the current post-amplifier gain attenuation.

Post-Amplifier Gain Attenuation

<value>	Argument	Gain Attenuation
0		0.0177112
1		0.0219618
2		0.0277711
3		0.0348555
4		0.0442779
5		0.0549046
6		0.0694277
7		0.0871389
8		0.112112
9		0.139018
10		0.175791
11		0.220636
12		0.280899
13		0.348315
14		0.440449
15		0.552809

Command Syntax: :CALIBRATE:PAGAIN CHANNEL<N>, <value>

Where:

<N> ::= 1 through 4

<value> ::= 0 to 15

Example:

```
OUTPUT 707;":CALIBRATE:PAGAIN CHANNEL1, 1"
```

Query Syntax: :CALibrate:PAGain?

Returned Format:

```
[:CALibrate:PAGain CHANnel<N>] <value><NL>
```

Where:

<N> ::= 1 through 4

<value> ::= 0 to 15(integer—NR1 format)

Example:

```
DIM Gain$[100]
OUTPUT 707;":CAL:PAG?"
ENTER 707;Gain$
PRINT Gain$
END
```

**:SENSOR:
ATODVALUE?**

The :CHANNEL<N>:SENSOR:ATODVALUE? query outputs the last converted A/D reading of the peak power sensor's temperature thermistor circuit.

Query Syntax: :CHANnel<N>:SENSOR:ATODVALUE?

Where:

<N> ::= 1 or 4

Returned Format:

[:CHANnel<N>:SENSor:ATODvalue] <value><NL>

Where:

<N> ::= 1 or 4

<value> ::=A/D value (exponential-NR3 format)

Example:

```
DIM Atod$[100]
OUTPUT 707;":CHAN1:SENS:ATOD?"
ENTER 707;Atod$
PRINT Atod$
END
```

SERIAL:SENSOR

The command :SERIAL:SENSOR is used to program a new serial number into the peak power sensor. This command permanently changes the serial number stored in the EEPROM of the peak power sensor. This number should always agree with the serial number on the peak power sensor case. It is normally used when the peak power sensor's diode and EEPROM are replaced.

Command Syntax: :SERial:SENSor CHANnel<N>,<string>

Where:

<N> ::= 1 or 4

<string> ::= peak power serial number in the form 1234A56789

Example:

```
OUTPUT 707;":SERIAL:SENSOR CHANNEL1, 1234A56789"
```

Query Syntax:**Note**

The query form of the command :SERIAL:SENSOR does not exist. Use the query :CHANNEL<N>:SENSOR? to read the current serial number of the peak power sensor. Besides the serial number, the query returns the model number of the sensor and the calibration date.

:CHANnel<N>:SENSor?

Where:

<N> ::= 1 or 4

Returned Format:

```
[:CHANnel<N>:SENSor] <Model_num>,<serial_num>,<cal_date>
```

Where:

<N> ::= 1 or 4

<Model_num> ::= HP84812A, 84813A, or 84814A

<serial_num> ::= In the form 1234A56789

<cal_date> ::= YYMMDD (YY is the year.

MM is the month. DD is the date.)

Example:

```
DIM Sensor$[100]
OUTPUT 707;":CHAN1:SENS?"
ENTER 707;Sensor$
PRINT Sensor$
END
```

STICKDAC

The command `:CALIBRATE:STICKDAC` is used to set the stickdac voltage on any channel. The stickdac voltage may be reset by a chopping cycle, which may be caused by a change in temperature at the peak power sensor, a range change, etc. To avoid the reset, under the service menu of the Utility Menu, set "Chopping" to OFF. Do not make a range change once the command has been used. When finished using the command, remember to set "Chopping" to ON.

The `:CALIBRATE:STICKDAC` query returns the current stickdac voltage for the specified channel.

Command Syntax: `:CALibrate:STICKdac CHANNEL<N>,<value>`

Where:

`<N> ::= 1 through 4`

`<value> ::= 0.5 volts to 1.00 volt`

Example:

```
OUTPUT 707;":CALIBRATE:STICKDAC CHANNEL1 0.5"
```

Query Syntax: `:CALibrate:STICKdac? CHANnel<N>`

Where:

`<N> ::= 1 through 4`

Returned Format:

`[:CALibrate:STICKdac CHANnel<N>] <value><NL>`

Where:

`<N> ::= 1 through 4`

`<value> ::= 0.5 volts to 1.00 volts (exponential-NR3 format)`

Example:

```
DIM Stic$[100]
OUTPUT 707;":CAL:STIC? CHAN1"
ENTER 707;Stic$
PRINT Stic$
END
```

ZVALUE

The :CALIBRATE:ZVALUE query outputs the sum of the zero offset input with :SYSTEM:EEROMSZERO and any delta added by a front panel manual zeroing. This command could be used to check the overall health of the peak power sensor and the Peak Power Analyzer when a zeroing problem shows up.

Query Syntax: :CALIBRATE:ZVALUE?

Where:

<N> ::= 1 or 4

Returned Format:

[:CALibrate:ZVALUE] <value><NL>

Where:

<N> ::= 1 or 4

<value> ::= total zero offset (exponential-NR3 format)

Example:

```
DIM Value$[100]
OUTPUT 707;":CAL:ZVALUE?"
ENTER 707;Value$
PRINT Value$
END
```

selftest menu

The Peak Power Analyzer is designed to perform internal diagnostics. This selftest submenu tests the Peak Power Analyzer to determine potential calibration errors.

Note



Before performing any self test, do a key down power-up. This resets many critical parameters to known values and assures that erroneous test failures do not occur. Perform a key down power-up by holding down any key and turning the Peak Power Analyzer off then back on.

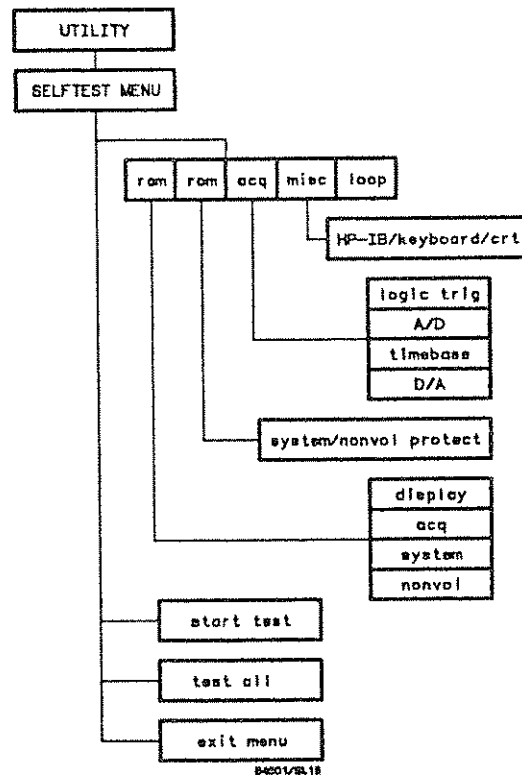

Figure 5-2. Selftest Menu

The Peak Power Analyzer self-diagnostics and selftests are designed to run operational tests on the following:

- ram
- rom
- acquisition
- miscellaneous

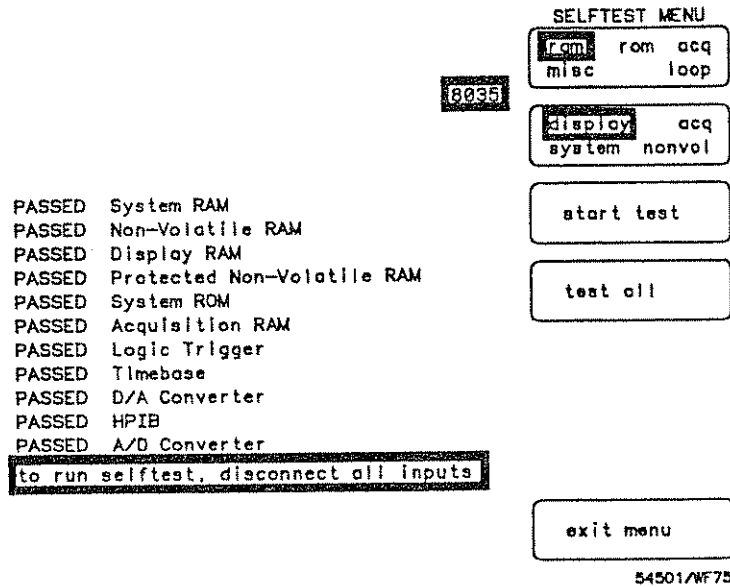

Figure 5-3. Results of Selftest

ram Test The ram test is a multiple selection field. The options are:

- display
- acquisition
- system
- unprotected nonvolatile memory

rom Test Two rom tests are available:

- system
- protected nonvolatile memory

acquisition Test Four acquisition tests are available:

- logic trigger
- A/D
- timebase
- D/A

miscellaneous Tests Three miscellaneous tests are available:

- HP-IB
- keyboard
- crt

Vertical Calibration Error Codes

When a vertical calibration has been completed, the following will be displayed if no errors were detected. The pattern represents four bytes. The most significant bit (MSB) and the least significant bit (LSB) have been indicated.

(MSB)→ - - - - - ←(LSB)

However, if an error was detected, a bit pattern similar to the following may be displayed:

(MSB)→ 0 0 0 0 0 0 0 0 0 0 1 0 0 0 0 ←(LSB)

By noting the displayed bytes and using the following tables, the most likely assembly responsible for the failure can be determined.

For example, if the previous bytes (0000 0000 0001 0000) represented the Power Channel Gain Calibration, bit four indicates that the A6 Baseband Board could be at fault.

Note



The Peak Power Analyzer contains two identical A6 Baseband Board assemblies, one for channel 1 and the other for channel 4. The upper assembly is for channel 4 and the lower assembly is for channel 1. Figure 2-14, in the Troubleshooting chapter, shows the location of the major assemblies in the instrument.

If the "Replace Assembly" column indicates that the failure could be the A1 Control Board or the A6 Baseband Board. Swap the A6 Baseband Board Assemblies, and run the vertical calibrations again. If the failure follows the baseband assembly, you can feel confident that the baseband assembly should be replaced.

Table 5-1. Vertical Calibration

Calibration	Bit	Replace Assembly ¹
Power Channel Gain Calibration	0	A6 Baseband Board
	1	A6 Baseband Board
	2	A6 Baseband Board
	3	A6 Baseband Board
	4	A6 Baseband Board
	5	A6 Baseband Board
	6	A6 Baseband Board
	7	A6 Baseband Board
	8	A6 Baseband Board
	9	A6 Baseband Board
	10	A6 Baseband Board
	11	A6 Baseband Board
	12	A6 Baseband Board
	13	Bit Not Used
	14	Bit Not Used
	15	Replace A2U2 and A2U3

¹ If both channel 1 and channel 4 are failing, the A1 Control Board probably should be replaced.

Table 5-1. Vertical Calibration

Calibration	Bit	Replace Assembly
Power Channel Trigger Calibration	0	Index Bit
	1	Index Bit
	2	Index Bit
	3	Index Bit
	4	Bit Not Used
	5	Bit Not Used
	6	A1 Control Board or A6 Baseband Board
	7	A1 Control Board or A6 Baseband Board
	8	Bit Not Used
	9	A1 Control Board or A6 Baseband Board
	10	A1 Control Board or A6 Baseband Board
	11	A1 Control Board or A6 Baseband Board
	12	A1 Control Board or A6 Baseband Board
	13	A1 Control Board or A6 Baseband Board
	14	A1 Control Board or A6 Baseband Board
	15	Replace A2U2 and A2U3

Table 5-1. Vertical Calibration (continued)

Calibration	Bit	Replace Assembly
Voltage Gain Calibration	0	A1 Control Board
	1	A1 Control Board
	2	A1 Control Board
	3	A1 Control Board
	4	A1 Control Board
	5	A1 Control Board
	6	A1 Control Board
	7	A1 Control Board
	8	A1 Control Board
	9	Bit Not Used
	10	Bit Not Used
	11	Bit Not Used
	12	Bit Not Used
	13	Bit Not Used
	14	Bit Not Used
	15	Replace A2U2 and A2U3

Table 5-1. Vertical Calibration (continued)

Calibration	Bit	Replace Assembly
Voltage Offset Calibration	0	A1 Control Board
	1	A1 Control Board
	2	A1 Control Board
	3	A1 Control Board
	4	A1 Control Board
	5	A1 Control Board
	6	Bit Not Used
	7	Bit Not Used
	8	A1 Control Board
	9	A1 Control Board
	10	A1 Control Board
	11	A1 Control Board
	12	Bit Not Used
	13	Bit Not Used
	14	Bit Not Used
	15	Replace A2U2 and A2U3

Table 5-1. Vertical Calibration (continued)

Calibration	Bit	Replace Assembly
Voltage Trigger Level Calibration	0	A1 Control Board
	1	A1 Control Board
	2	A1 Control Board
	3	A1 Control Board
	4	A1 Control Board
	5	A1 Control Board
	6	A1 Control Board
	7	A1 Control Board
	8	A1 Control Board
	9	A1 Control Board
	10	A1 Control Board
	11	A1 Control Board
	12	A1 Control Board
	13	A1 Control Board
	14	A1 Control Board
	15	Replace A2U2 and A2U3

Table 5-1. Vertical Calibration (continued)

Calibration	Bit	Replace Assembly
Power Channel Gain Calibration	0	A6 Baseband Board
	1	A6 Baseband Board
	2	A6 Baseband Board
	3	A6 Baseband Board
	4	A6 Baseband Board
	5	A6 Baseband Board
	6	A6 Baseband Board
	7	A6 Baseband Board
	8	A6 Baseband Board
	9	A6 Baseband Board
	10	A6 Baseband Board
	11	A6 Baseband Board
	12	A6 Baseband Board
	13	A6 Baseband Board
	14	A6 Baseband Board
	15	Replace A2U2 and A2U3

Index

- A** abbreviations, 4-1
accessories, ESD, 1-4
acquisition test, 5-12

- C** calibration, after repair, 2-6
calibration, delay, 2-7
calibration guide, 1-1
calibration, vertical, 2-7
check digit, 4-1
cleaning, 2-5
cleaning intervals, 2-5
cleaning solution, 2-5
component-level information, 1-1, 2-4
component locations, 2-4

- D** diagnostics, 5-11
disassembly procedures, 3-1

- E** electrostatic discharge, 1-2
errata, 1-2
error codes, vertical calibration, 5-14
ESD, 1-2
exchange assemblies, 4-2

- F** failure codes, vertical calibration , 5-1
firmware, removing and installing, 2-6

- H** hardware, inch, 2-4
hardware, metric, 2-4

- M** manual organization, 1-1
manual updates, 1-2

- P** packaging, 1-5
packing material, 1-6
parts list, backdating, 4-2
parts list, updating, 4-3
parts, ordering, 4-3
power, applying, 2-2

- R** ram Test, 5-12
 - recommended spares list, 4-3
 - recommended test equipment, 1-6
 - remote commands, service , 5-3
 - replaceable mechanical parts, 4-2
 - rom Test, 5-12

- S** safety, 1-1, 2-2
 - safety check, after service, 2-3
 - screwdriver, Pozidriv, 2-4
 - screwdriver, TORX®, 2-4
 - selftest, 5-11
 - selftest menu, 5-11
 - self-tests, 5-1
 - serial number, 1-2
 - serial number prefix, 1-2
 - service accessories, 2-3
 - service aids, 2-5
 - service features, 5-1
 - service kit, 1-2, 2-3, 3-2
 - service menu, 5-1
 - service notes, 2-5
 - service remote commands, 5-1
 - service, return for, 1-5
 - service tags, 1-5
 - shipping container, 1-6

- T** test equipment, 2-3
 - test points, 2-5
 - theory of operation, block diagram 1, 2-9
 - troubleshooting, 2-1
 - troubleshooting, block diagram, 2-11
 - troubleshooting, methods, 2-1
 - troubleshooting, procedural, 2-37

- V** vertical calibration, 5-14

REGIONAL SALES AND SUPPORT OFFICES

For information relating to Sales or Support of Hewlett-Packard products, first contact your local Hewlett-Packard office listed in the white pages of your telephone directory. If none is listed locally, contact Hewlett-Packard at one of the offices listed below to obtain the address or phone number of the Sales or Support office nearest you.

The format for telephone numbers is listed as: (country code/area code or city code) local number. For example, at European Operations HQ, the main site number is listed as: (41/22)780.8111; 41 is the country code, 22 is the city code, and 780.8111 is the local number.

EUROPEAN MULTICOUNTRY

(Scandinavia, Middle East,
Africa, Eastern Europe)
Hewlett-Packard S.A.
150, route du Nant-d'Avril
P.O. Box 1217 Meyrin
2/Geneva
Switzerland
Tel: (41/22)780.8111
Fax: (41/22)780.8609

FRANCE

Hewlett-Packard France
Parc d'Activite du Bois Briard
2, avenue du Lac
91040 Evry Ce'dex
France
Tel: (33/1)69 91 80 00
Fax: (33/1)69 91 84 32

GERMANY

Hewlett-Packard GmbH
Herrenberger Strasse 130
D-7030 Boblingen
West Germany
Tel: (49/7031)14-0
Fax: (49/7031)14-2999

ITALY

Hewlett-Packard Italiana
S.p.A.
Via Giuseppe di Vittorio, 9
20063 Cernusco sul Naviglio,
Milan
Italy
Tel: (39/2)921 001
Fax: (39/2)921 044 73

UNITED KINGDOM

Hewlett-Packard Ltd.
Nine Mile Ride
Wokingham, Berkshire RG11
3LL
England
Tel: (44/344)773100
Fax: (44/344)763526

AUSTRALASIA REGION

Hewlett-Packard Australia Ltd.
31-41 Joseph Street
Blackburn, Victoria 3130
Australia
Tel: (61/3)895-2895
Fax: (61/3)898-7831

CANADA

Hewlett-Packard (Canada)
Ltd.
6877 Goreway Drive
Mississauga, Ontario L4V 1M8
Canada
Tel: (1/416)678-9430
Fax: (1/416)678-9421

FAR EAST REGION

Hewlett-Packard Asia Ltd.
22nd Floor
West Tower, Bond Centre
89 Queensway, Central
Hong Kong
Tel: (852)848-7777
Fax: (852)868-4997

JAPAN

Yokogawa-Hewlett-Packard
Ltd.
3-29-21, Takaido-Higashi
Suginami-Ku, Tokyo 168
Japan
Tel: (81/3)331-6111
Fax: (81/3)331-6631

LATIN AMERICA REGION

HP Mexico, S.A. de C.V.
Monte Pelvovs No. 111
Fracc. Lomas de Virreyes
11000 Distrito Federal
Mexico
Tel: (52/5)202 01 55
Fax: (52/5)540 42 08

EASTERN U.S.A. REGION

Hewlett-Packard Company
4 Choke Cherry Road
Rockville, MD 20850, USA
Tel: (1/301)670-4300
Fax: (1/301)670-4531

MIDWEST U.S.A. REGION

Hewlett-Packard Company
5201 Tollview Drive
Rolling Meadows, IL 60008,
USA
Tel: (1/708)255-9800
Fax: (1/708)259-4995

SOUTHERN U.S.A. REGION

Hewlett-Packard Company
2015 South Park Place
Atlanta, GA 30339, USA
Tel: (1/404)955-1500
Fax: (1/404)980-7669

WESTERN U.S.A. REGION

Hewlett-Packard Company
5161 Lankershim Blvd.
N. Hollywood, CA 91601-
3794,
USA
Tel: (1/818)505-5600
Fax: (1/818)505-5875

OTHER INTERNATIONAL AREAS

Hewlett-Packard Company
3495 Deer Creek Road
Palo Alto, CA 94304-1316,
USA
Tel: (1/415)857-5027
Fax: (1/415)857-7045

